

North American Automatic Shutoff Valves Manual Reset & Motorized Specifications and Capacities

DESIGN DETAILS

Top Assembly

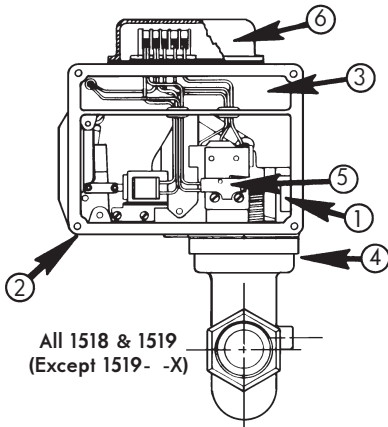

Large, two-color OPEN/SHUT indicator ① provides easy identification of valve position. Built-in wiring compartment ③ and terminal block ⑥ eliminates need for external junction box.

Terminal block ⑥ includes 12 number-coded positions.

Auxiliary switches ⑤ provide DPDT proof-of-open and SPDT "proof-of-closure" to meet insurance and approval requirements.

Good practice dictates that auxiliary switches used in main automatic shutoff valves normally be used for signal duty only.

In a block-and-vent system, blocking valve and normally open vent valve may be powered through the "proof-of-closure" switch of the main automatic shutoff valve; but all three valves must be powered through the appropriate normally open flame relay contact.

Enclosure ② meets NEMA 1, 3, 3S, 4 and 12, and CSA 2, 3 and 4 standards (when suitable electrical connections are made).

Lubrication-free design means minimal maintenance requirements. Field-rotatable top assembly ④ provides four positions for complete piping convenience.

Valves feature solenoid-actuated internal latching mechanism, except 1519- -X or 1519U- -X, which have rack-and-pinion/solid state/magnetic clutch design.

When a motorized valve is energized, drive motor opens valve in 6 to 12 seconds, dependent on valve size.

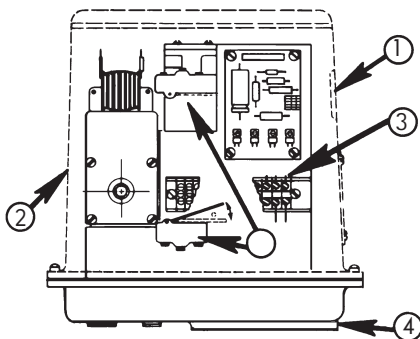

1519- -X Only

Valve Body

Metal-to-metal seating doesn't wear out; it "wears in." Disc wipes valve seat clean during each operation ⑦.

Rising stem design with straight-through flow ⑧ reduces pressure drop. Cast iron or cast steel body ⑨ to meet application requirement.

Built-in over-travel at closed position for positive shut-off.

Test connections provided both upstream and downstream of valve disc.

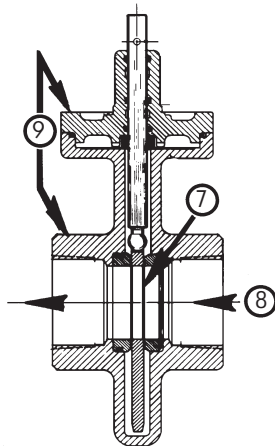

Accessories

Companion Flange Sets (flat-faced) facilitate installation of flanged valves. Order separately.

Wheel and Chain assemblies allow operation of manual valves in otherwise inaccessible overhead locations. To order, specify valve with remote reset wheel and chain (2-8628-1 through -5).

Every valve is operationally tested and meets requirements of ANSI B16.104 Class VI seat leakage when it leaves our plant.

WARNING: Valve leak test should be performed on a quarterly basis to assure continued safe and reliable operation. Each valve should be checked with available line pressure. Absolute zero leakage may not be obtained in the field. Any valve that exceeds the allowable leakage, as set forth by your local codes or insurance requirements (15 bubbles per minute), should be removed from service and your North American representative should be contacted.

CAPACITIES and VALVE SELECTION CHARTS

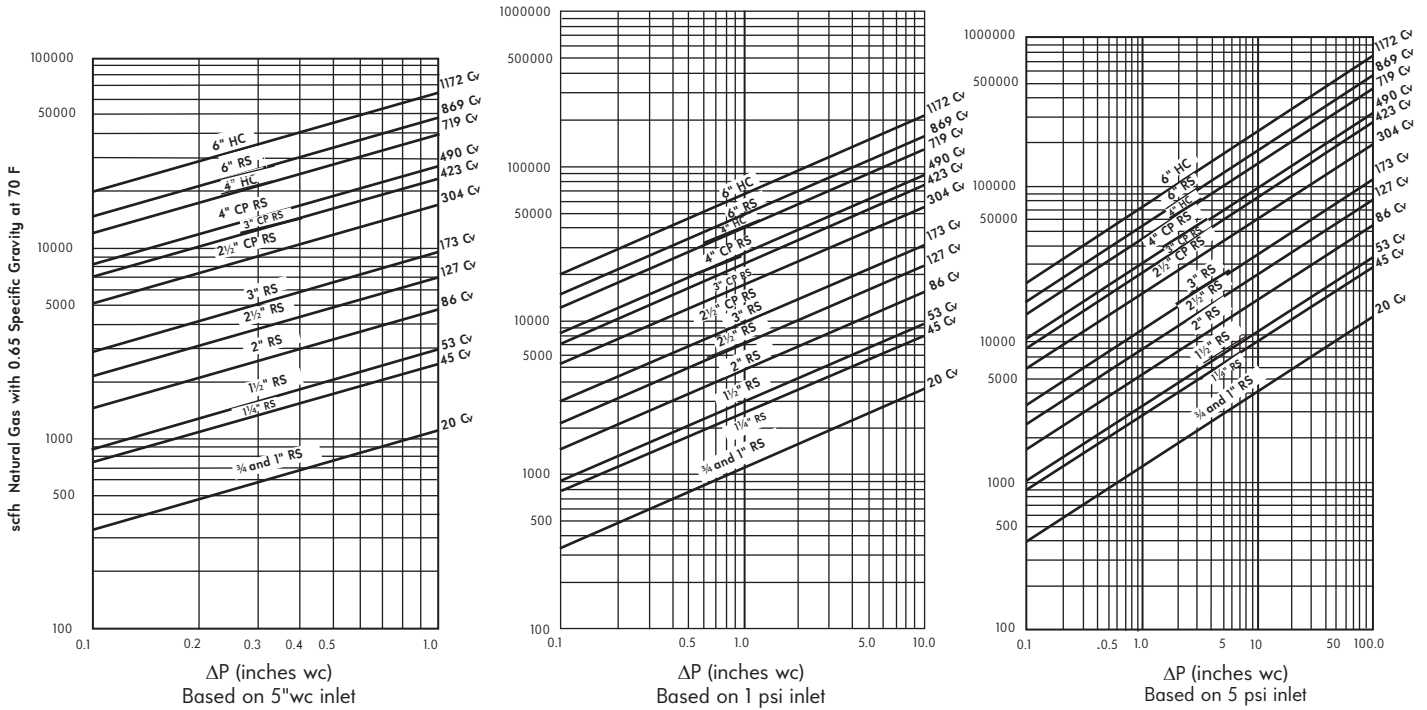

To calculate gas flow at other pressures: $Q = 1360 C_v \left[\frac{(P_1^2 - P_2^2)}{2 GT} \right]^{1/2}$

- Q = scfh
- G = specific gravity
- P₁ = inlet psia
- P₂ = outlet psia
- T = temp. (460 + F)

APPROXIMATE OIL CAPACITY	Valve	gph
Based on #2 Fuel Oil (60 F, 30°API) at ΔP = 1 psig	1518/19-0	1200
	1518/19-1	1300
	1518/19-2	2900

NOTE — For quick sizing: Q = 140 (Cv) for 3 osig ΔP at 3 psig inlet. Q = 145 (Cv) for 3 osig ΔP at 5 psig inlet.
 Q = 165 (Cv) for 3 osig ΔP at 10 psig inlet. Q = 482 (Cv) for 1 psig ΔP at 25 psig inlet.

Valve Size	Cv	scfh Nat'l Gas at 1 osig ΔP w/2 psig inlet	UL/FM/CGA SANCTIONED		
			Manual Reset	Motorized	Max. psi at Inlet†
-0 (3/4")	20	1 460	1518-0	1519-0	125
-1 (1")	20	1 540	1518-1 1518-1-S	1519-1 1519-1-S	125
-2 (1 1/4")	45	3 390	1518-2	1519-2	100
-3 (1 1/2")	53	4 080	1518-3 1518-3-S	1519-3 1519-3-S	70
-4 (2")	86	6 600	1518-4 1518-4-S	1519-4 1519-4-S	70
-5 (2 1/2")	127	9 800	1518-5(F)	1519-5(F)	40
	304	23 400	1518-5-E(F) 1518-5-EFS	1519-5-E(F) 1519-5-EFS	50
-6 (3")	173	13 300	1518-6	1519-6	30
	423	33 300	1518-6-E(F) 1518-6-EFS	1519-6-E(F) 1519-6-EFS	40
-7 (4")	490	38 600	1518-7-EF 1518-7-EFS	1519-7-EF 1519-7-EFS	40
	719	56 600	—	1519-7-XF 1519-7-XFS	60
-8 (6")	869	68 400	1518-8-F 1518-8-FS	—	20
	1172	92 300	—	1519-8-XF 1519-8-XFS	50

WARNING: Situations dangerous to personnel and property may exist with the operation and maintenance of any combustion equipment. The presence of fuels, oxidants, hot and cold combustion products, hot surfaces, electrical power in control and ignition circuits, etc., are inherent with any combustion application. Parts of this product may exceed 160F in operation and present a contact hazard. Fives North American Combustion, Inc. urges compliance with National Safety Standards and insurance Underwriters recommendations, and care in operation.

† Maximum operating pressure differential must not exceed the maximum inlet pressure.
 (F) = Optional Flanged S = Steel Body E = Extra Capacity
 F = Standard Flanged U = Non-sanctioned X = Rack and Pinion Operator

ELECTRICAL DATA

General

All standard shutoff valves are designed for operation on 115 V 60 Hz power supply. Optional voltages, Hz, direct current, or special switches, involve extra cost and extended delivery. Specify power characteristics when ordering.

A solenoid or circuit board is energized whenever valve is powered. Holding current volt-amperes are continuous once energized. Motor on any 1519 Valve is powered only during the opening stroke. The normally closed contact of a limit switch breaks motor circuit when full-open position is reached.

Flow begins within 1 second of powering. Full closure is complete within 1 second after de-energizing.

Series 1519- -X only

Standard 120 V power input is converted by a circuit board (no solenoid) to 90 V dc output to a magnetic clutch that is energized whenever valve is powered.

Circuit board components also act as a time delay, allowing 1/10 second response lag after main power interruption (this helps avoid nuisance shutdowns).

Valve Opening Times

1519-7-X (4")	12 seconds on 60 Hz
1519-8-X (6")	12 seconds on 60 Hz
All other 1519's	6 seconds on 60 Hz

WARNING: Do not attempt field repair of valve body, top assembly, or motor drive unit. Any alterations could be dangerous, and will void all warranties.

Volt-ampere (VA) ratings

All solenoid, circuit board, and motor ratings are shown in Table I. Total connected load on any valve should not exceed 2000 VA. This limitation includes the maximum consumption shown in Table I plus the VA consumption of external equipment powered by the auxiliary switches at any one time.

TABLE I

Type	Valve Size (inches)	Series	VA Ratings (ac operation)	
			Opening	Holding
Manual Reset	3/4-3	1518	22	22
	6	1518	34	34
	2 1/2-4	1518- -E	34	34
Motorized	3/4-3	1519	220	22
	2 1/2-4	1519- -E	232	34
	4-6	1519- -X	376	8

Wiring Diagrams

Each automatic shutoff valve includes one of the wiring diagrams shown below and on Page 4. Switch contacts are shown with the valve shut, unpowered.

Wiring shown above the terminal strip is internal. Wiring below terminal strip is external (field), as required.

All wires are number-coded as shown to match terminals. Terminals "2" and "DC" are neutral; all others are hot.

TYPICAL WIRING FOR ALL VALVES EXCEPT 1519- -X

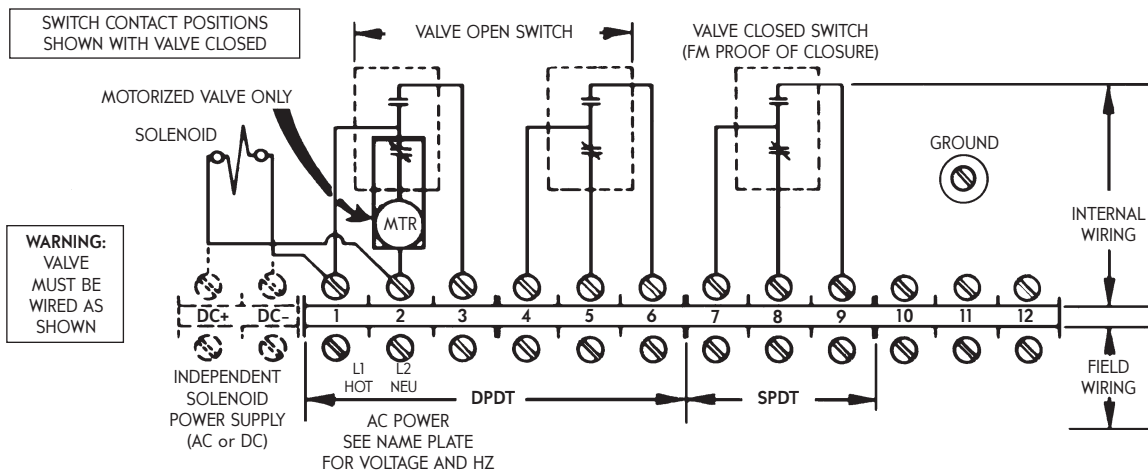

SWITCH RATINGS

Total connected load not to exceed 1700 VA including values from Table I

SPDT		DPDT	
125 V ac-	15 amp	125 V ac-	10 amp
250 V ac-	15 amp	250 V ac-	10 amp
125 V dc-	0.5 amp	125 V dc-	0.3 amp
250 V dc-	0.25 amp	250 V dc-	0.15 amp

TYPICAL SWITCH ACTION

(O = Open contacts; X = Closed contacts between indicated terminals.)

Valve Position	Valve Open Switch			Valve Closed Switch	
	1-3	4-5	4-6	7-8	7-9
Fully Closed	O	X	O	X	O
Intermediate	O	X	O	O	X
Fully Open	X	O	X	O	X

VALVE BODY AND TRIM

Standard 1518 Manual Reset and 1519 Motorized Valves have cast iron bodies with internal materials listed in table below under "Standard Trim." Cast steel bodies are available. They are specified by adding an "S" after the code number for pipe size. *Example:* 1518-4-S.

Body and Bonnet Specifications		Standard Body and Bonnet	"S" Body and Bonnet
A	Material	CI, G3000, CL30	Cast Steel
B	ASTM Spec	A159	A216-WCB

Other trim packages are available per request. Please contact engineering. i.e. different body, seat, disc, spring pin, and body seal and bumper materials are available.
*Body seal bumper.

Note: For "U" valves, please submit fuel analysis to Fives Cleveland home office to determine suitability of valves.

Valve Internals

Item No.	Description	Standard Trim			
		¾ - 2"	2 ½ - 3"	4 - 6"	2 ½ - 4"
A	Body	Cast Iron			
B	Bonnet	ASTM A126, Class B			
3	Seat	400 SS			
4	Disc	Hardened Ductile Iron			
5	Follower Ring	PEEK			
6	Seat O-Ring*	Buna N			
7	Body O-Ring*	Buna N			
8	Wavy Spring	300 SS			
9	Stem	17-4 PH SS			
10	Spring pin (when required)	Carbon Steel			
11	Stem O-Ring*	Buna N			
12	Striker Plate	17-7 PH SS			
13	Bumper*	Buna N			
—	Clevis	Ductile Iron			

- ① Compression Ring
- ② For 6" 808, and 4" & 6" 7000 valves only; not shown in illustration

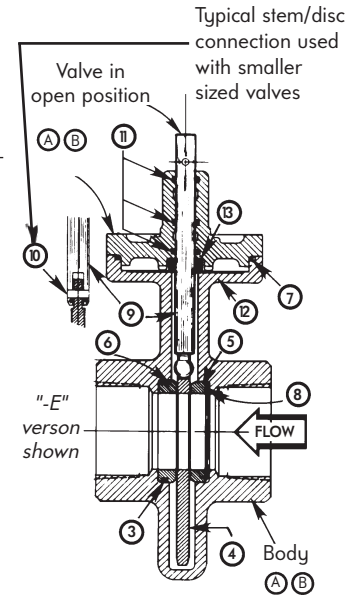

WIRING FOR 1519- -X ONLY

SWITCH CONTACT POSITIONS SHOWN WITH VALVE CLOSED

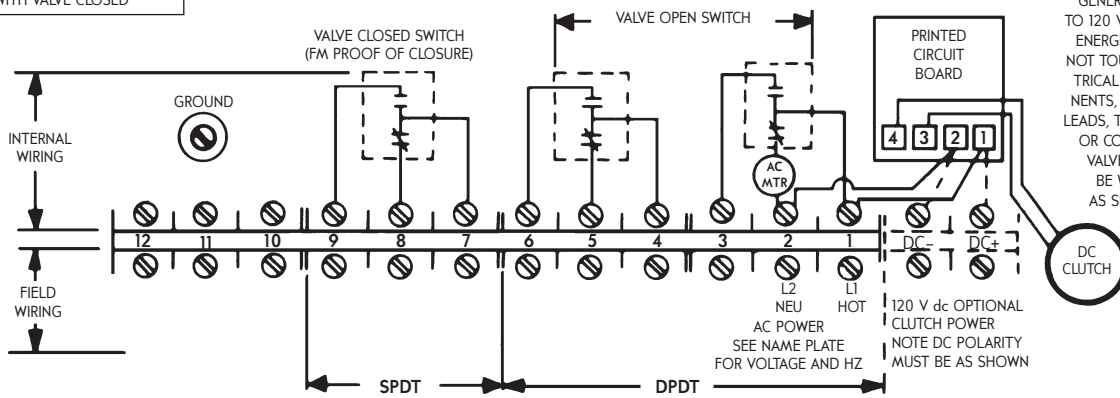

WARNING:
CIRCUIT BOARD GENERATES 90 TO 120 V dc WHEN ENERGIZED. DO NOT TOUCH ELECTRICAL COMPONENTS, EXPOSED LEADS, TERMINALS, OR CONTACTS. VALVE MUST BE WIRED AS SHOWN.

SWITCH RATINGS

Total connected load not to exceed 1600 VA including values from Table I

SPDT		DPDT	
125 V ac-	20 amp	125 V ac-	10 amp
250 V ac-	20 amp	250 V ac-	10 amp
125 V dc-	0.5 amp	125 V dc-	0.3 amp
250 V dc-	0.25 amp	250 V dc-	0.15 amp

TYPICAL SWITCH ACTION

(O = Open contacts; X = Closed contacts between indicated terminals.)

Valve Position	Valve Open Switch		Valve Closed Switch	
	1-3	4-5	4-6	7-8
Fully Closed	O	X	O	X
Intermediate	O	X	O	X
Fully Open	X	O	X	X