

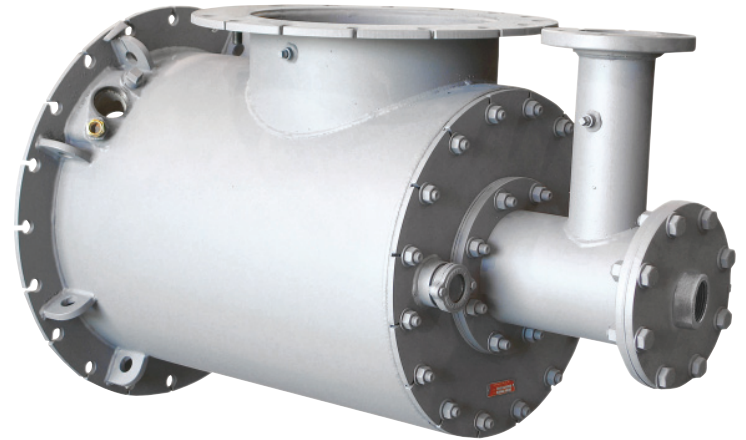

- 3 to 40 million Btu/hr
- For applications up to 2600 F
- Combustion air temperature up to 1200 F
- Fuel gases (500 Btu/ft³ or higher)
- Sharp, well-defined flames
- Excellent performance with cold or hot air



4821 Hot Air Magna-Flame™ Burners operate with hot air from recuperators or other heat recovery devices to save energy on furnaces, such as steel reheat, aluminum melting, process heaters, and other high temperature applications. Normal capacities are rated at 1000 F air at a pressure of 10"wc.

CONSTRUCTION. Bodies are fabricated heavy-gauge carbon steel and lined with ceramic fiber and castable refractory. Internal parts are heat-resistant alloy and the stabilizing disc is faced with high alumina refractory.

OPERATION. Gas flames are stable in cold, tight combustion chambers with ambient or high temperature combustion air. Under these conditions, the flame is semi-luminous.

The 4821 burner incorporates a low fire air jet. Air (at 60 F) is supplied to the connection at 1.0 psi (27.7"wc) and is introduced into the center of the flame to enhance flame shape throughout turndown conditions. See table below for air jet capacities.

For applications that benefit from high velocity, such as aluminum melters and holders, steel reheat furnaces or others, the 4821 is available in an "R-version". The refractory tile shape of the R version is reduced (converging) to produce high hot-gas exit velocities, resulting in increased convective heat transfer and at the same time entrainment of surrounding furnace gases resulting in low NO_x emissions. For extremely low NO_x applications, consult Fives North American about combining the R-version burner with low NO_x injection (LNI) technology.

CONTROL. The burner operates with main air pressures from 0.2 to 10"wc. For stoichiometric firing, required natural gas pressure is a minimum 60 percent of the air pressure. Either a cross-connected regulator system or electronic mass flow control system can be used.

IGNITION AND FLAME SUPERVISION. Magna-Flame burners should be pilot ignited ①. Pilot ignition must occur at 1" wc main air pressure or less. Appropriate 4014 gas-boosted pilots are to be used with this burner (sold separately), and are shown on the dimension table. Pilot operation must be interrupted to prevent overheating of the mounting. Self-checking UV scanners (sold separately) are recommended for flame supervision. See Bulletin 8832 for selection of UV adapters. It is possible for a UV scanner mounted on this burner to sight flame(s) of other burners in the same firing chamber. Consult Fives North American for configuration guidance on multiple burner applications.

INSTALLATION. The burner does not include a tile. The tunnel shape shown on the dimension drawing (page 2) must be built into the combustion chamber wall. See Supplement DF-M1 for installation recommendations.

COMBUSTION AIR CAPACITY, scfh (for Btu/hr capacity, multiply scfh by 100)

Standard Tile	Burner Designation Reduced Port Tile	1000 F Air at 10"wc ΔP	60 F Air at 10"wc ΔP	Jet Air, scfh at 60 F with 27.7"wc ΔP	Flame Dimensions at 1000 F air ②	
					Length	Diameter
4821-9	4821-9-R	34,000	55,000	1,130	5'	2'
4821-10-A	4821-10-AR	40,000	67,000	1,850	5'	2'
4821-10-B	4821-10-BR	53,000	89,000	1,850	7'	2'
4821-12	4821-12-R	78,000	130,000	4,500	9'	3'
4821-14	4821-14-R	106,000	177,500	4,500	10'	4'
4821-16	4821-16-R	134,000	225,000	6,700	13'	4'
4821-18	4821-18-R	172,000	288,000	8,600	16'	5'
4821-20	4821-20-R	215,000	360,000	10,750	17'	5'
4821-22	4821-22-R	260,000	435,500	10,750	20'	5'

① Because of positive pressure in the burners, it is difficult to light with a torch unless the air is turned very low and a strong pressure torch is used.

② Subtract 10% from flame dimensions shown for reduced port tile "R" version.

WARNING: Situations dangerous to personnel and property may exist with the operation and maintenance of any combustion equipment. The presence of fuels, oxidants, hot and cold combustion products, hot surfaces, electrical power in control and ignition circuits, etc., are inherent with any combustion application. Parts of this product may exceed 160F in operation and present a contact hazard. Fives North American Combustion, Inc. urges compliance with National Safety Standards and insurance Underwriters recommendations, and care in operation.

DIMENSIONS in inches

DIMENSIONS SHOWN ARE SUBJECT TO CHANGE.
PLEASE OBTAIN CERTIFIED PRINTS FROM FIVES NORTH AMERICAN COMBUSTION, INC. IF SPACE LIMITATIONS OR OTHER CONSIDERATIONS MAKE EXACT DIMENSION(S) CRITICAL.

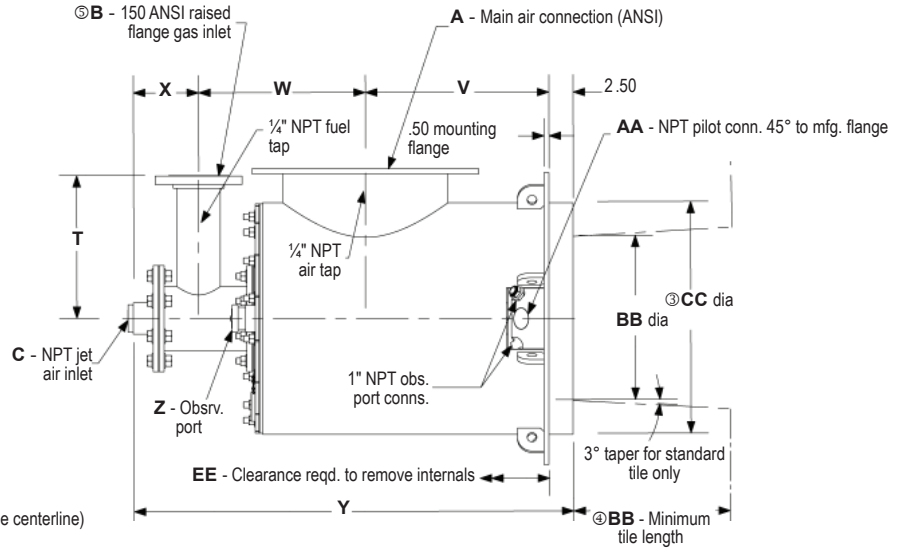
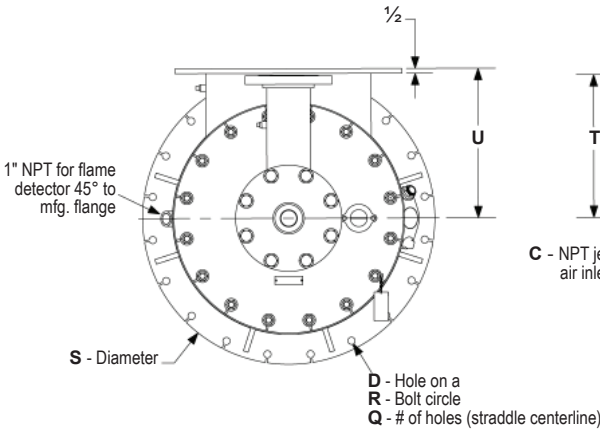
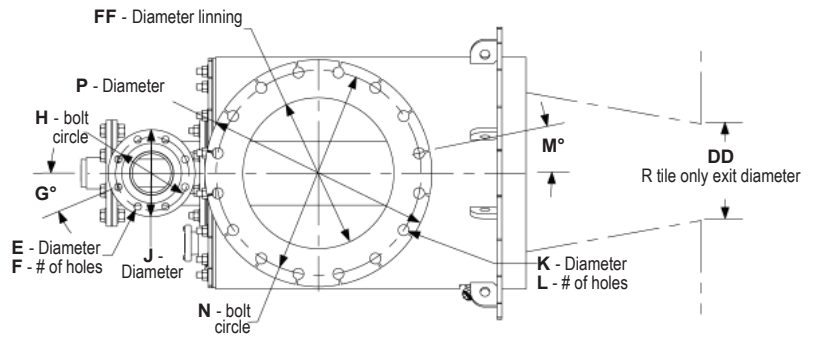

DIMENSIONS IN INCHES AND DEGREES

Burner Designation	A	B ^③	C	D	E	F	G°	H	J	K	L	M°	N	P	Q	R	S	T
4821-9	8	2.5	1	0.75	0.75	4	45	5.5	7	0.88	8	22.5	11.75	13.5	16	20.5	22.25	11.75
4821-10-A	10	2.5	1	0.75	0.75	4	45	5.5	7	1	12	15	14.25	16	16	20.5	22.25	11.75
4821-10-B	10	2.5	1	0.75	0.75	4	45	5.5	7	1	12	15	14.25	16	16	22.5	24.25	13.75
4821-12	12	3	1	0.75	0.75	4	45	6	7.5	1	12	15	17	19	16	24.5	26.25	14.75
4821-14	14	4	1	0.75	0.75	8	22.5	7.5	9	1.13	12	15	18.75	21	20	26.5	28.25	14.81
4821-16	16	4	1 1/4	0.75	0.75	8	22.5	7.5	9	1.13	16	11.25	21.25	23.5	20	28.5	30.25	14.81
4821-18	18	4	2	0.88	0.75	8	22.5	7.5	9	1.25	16	11.25	22.75	25	20	30.5	32.25	14.81
4821-20	20	6	2	0.88	0.88	8	22.5	9.5	11	1.25	20	9	25	27.5	24	32.5	34.25	15.5
4821-22	22	6	2	0.88	0.88	8	22.5	9.5	11	1.25	20	9	26	29.5	24	34.5	36.25	15.5

DIMENSIONS IN INCHES

Burner Designation	U	V	W	X	Y	Z	AA	BB ^④	CC ^③	DD	EE	FF	Estimated weight, lb	Recommended pilot assy.
4821-9	11	13	12.31	5.75	33.56	3/4	1.5	10	16	5.75	60	7	343	4014-2-T
4821-10-A	11	12.25	13.06	5.75	33.56	3/4	1.5	10	16	6.25	61	9	343	4014-2-T
4821-10-B	12.5	15	13.94	5.75	37.19	3/4	1.5	11	18	7	69	9	443	4014-2-T
4821-12	13.5	17.5	15.44	6.81	42.25	3/4	2	12.5	20	8.5	83	11	580	4014-3-AT
4821-14	14.5	18.5	16.88	7.69	45.56	3/4	2	14.75	22	10	86	13.63	715	4014-3-AT
4821-16	15.5	19	17.25	7.31	46.06	2	2	17	24	11.25	87	15.63	795	4014-3-AT
4821-18	16.5	19.5	18.88	7.5	48.38	2	2	19.25	26	12.75	92	17.63	915	4014-3-BT
4821-20	17.5	20.5	21.25	8.88	53.13	2	2	21.5	28	14.25	100	19.63	1035	4014-3-BT
4821-22	18.5	21.5	23.13	8.88	56	2	2	24	30	15.75	100	21.63	1152	4014-3-BT

- ③ Furnace opening should be 1/2" larger than dimension CC for 10A thru 14 and 3/4" larger than dimension CC for 16 thru 22.
- ④ Whenever the tile length is greater than BB × 1.2, the tile beyond BB should flare out at a 30° angle (60° included angle).
- ⑤ Flat face companion flange available upon request.

Arrangement Designators are specified relative to the main air connection at 12 o'clock and should be listed for **pilot, gas and flame supervision in that order.**

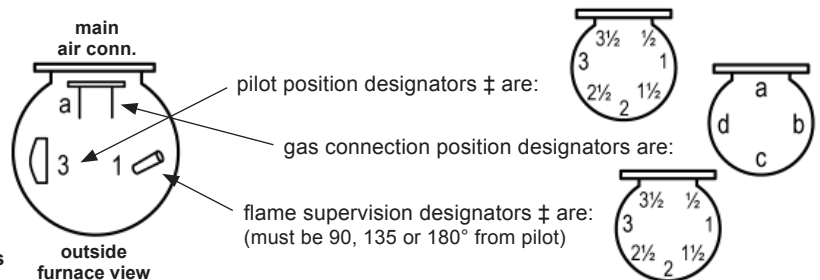

‡ Good practice dictates that neither the pilot nor the flame detector be below the centerline of a horizontally-mounted burner.

ORDER MUST SPECIFY: (1) Burner designation (such as 4821-14); (2) Arrangement designation for pilot, gas connection and flame safety positions in that order such as 4821-14, arrangement 3a1 (for the arrangement shown above).