

North American reGen® Gas Burners

4630 reGen Burners are made up of line burner sections to fire low temperature applications where heat must be distributed uniformly over a large area.

Direct fired air heating applications:

- Drying paints, textiles, metal parts, ink, etc.
- Recirculating core ovens.
- Cooking, evaporating, heating, etc. in the food industry.

Other Heating kettles; preheating metal bars, castings, etc.; glass lehrs and fire polishing.

reGen Burners are stable with up to 12"wc mixture pressure in air stream velocities as high as 2000 fpm. They can operate in ambient temperatures up to 400 F. Assemblies can fire in any direction, including down.

Flames are short and sharp at correct air/gas ratio, longer and yellow-tipped with rich mixtures. An assembly lights reliably from a single pilot. See Page 2 for 4630 selection information.

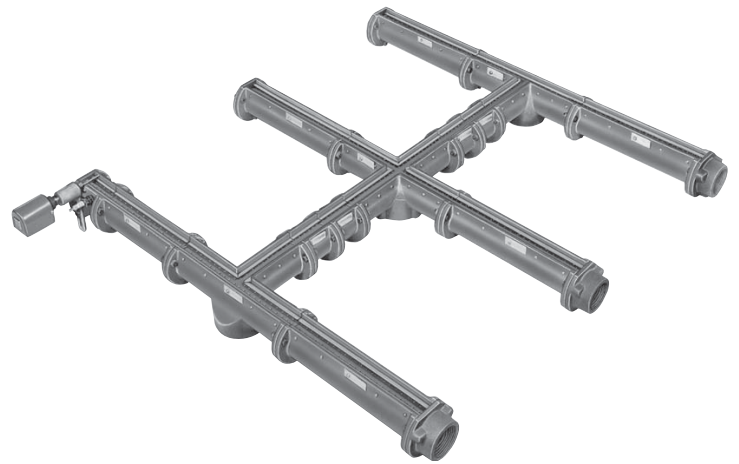

A typical reGen Burner assembly, with sections selected and arranged to fit a specific duct cross section with "J" flame rod adapter on pilot section.

Table 1. 4630 CAPACITIES and DRILLINGS

Btu/hr per ft at 4"wc mixture pressure	DRILLING				Btu/hr per ft at 4"wc mixture pressure	DRILLING			
	each outer row		inner row			each outer row		inner row	
	drill size	number of holes/ft	drill size	number of holes/ft		drill size	number of holes/ft	drill size	number of holes/ft
19 000	49	12	—	—	101 000	42	23	38	22
23 000	45	12	—	—	119 000	42	23	31	22
29 000	45	12	53	11	144 000	42	23	25	22
36 000	45	12	53	22	169 000	42	23	19	22
45 000	45	23	—	—	198 000	42	23	13	22
57 000	45	23	53	22	226 000	42	23	5	22
71 000	45	23	46	22	252 000	42	23	1	22
85 000	42	23	45	22	289 000	42	23	E	22

Drillings are different for the elbows in some larger sizes, but capacities per foot are the same. Mixture manifolds should not be larger than 4" pipe size because of flashback hazard.

4630 SELECTION

1. Sketch (to scale) burner layout that will provide uniform temperature distribution.
2. Determine total burner length this layout requires by adding together individual section lengths as indicated below. The "typical" assembly in the left photograph on Page 1 covers a 3' square area, using:

(6) 4630-E (12") and (4) 4630-S (3") straight sections
 (2) 4630-T tee section (1) 4630-X cross section
 (1) 4630-P pilot section (3) 2" inlet flanges

This results in 12' of total "burner length."

3. Divide total Btu/hr input requirement by total burner length.

Result will be Btu/hr per ft of 4630 Burner. Select appropriate burner capacity/drilling from Table I...at the 4"wc mixture pressure ratings shown, or higher or lower ratings if other mixture pressures are available (up to 12"wc maximum)--use the square root law or handbook tables for determining different ratings.

4. Select points at which air-gas mixture is to be fed into assembly:

A 2" end connection can handle up to 350 000 Btu/hr (at 4"wc).

A 3" connection can handle 800 000 Btu/hr (4630-B, -H, -T, and -X have 3" connections).

If multiple inlet connections are required, locate them so they feed approximately equal burner lengths.

5. "Fill in" assembly with appropriate straight and elbow section, inlet flanges, end plates, etc. If multiple mixers are used, mixer zones must be separated within burner assembly--use either 4-1739-1 separator plates or 4-3159-1 expansion ignition couplings.

6. To avoid dangerous flashback, mixture manifolds should not exceed 4" pipe size.

4630 Main Burner Sections

* Hardware Included

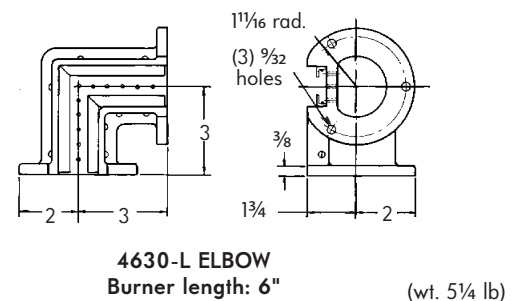
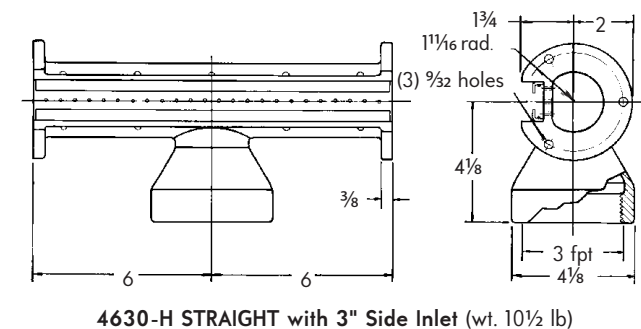
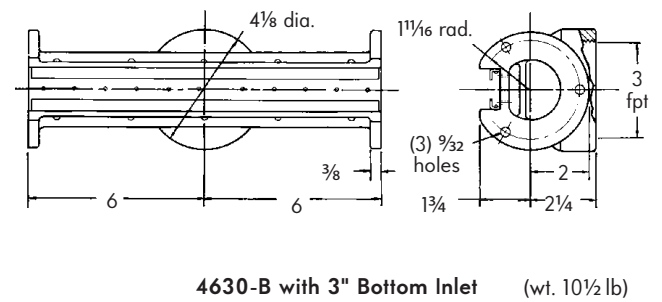
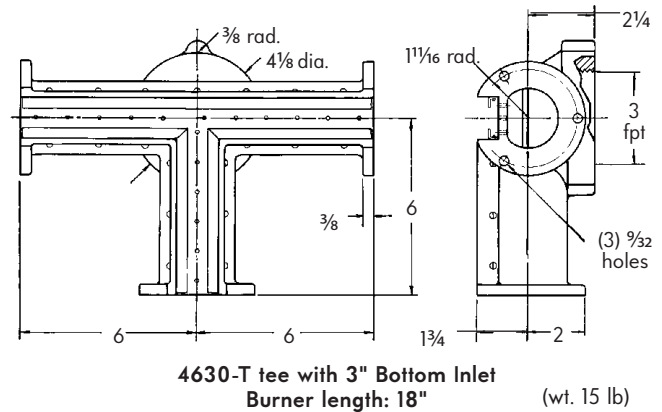
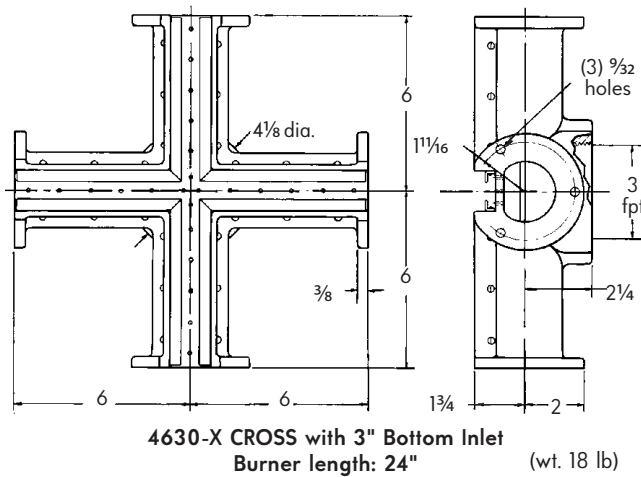
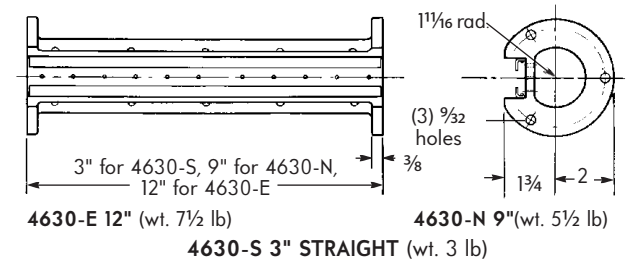

4630 Auxiliary Sections & Accessories

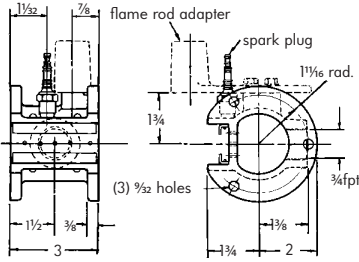

4630-P Pilot Section (wt. 4 lb)

Complete with spark plug, two separator plates, and provision for adding an 883_-J flame rod adapter. This 3" section has 3/4" bottom inlet and takes a 3065-0-7 Mixer (do not specify a capacity rating).

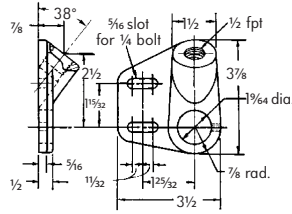

4-2408-3 Pilot and Flame Rod Bracket

(wt. 1 lb)

For mounting a 4021-15 or 4021-16 Pilot Tip and an "M" style flame rod adapter. Use with Part No. 4-2167-1.

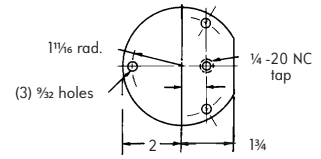

4-2167-1 Companion Endplate

(wt. 1 lb)

For mounting 4-2408-3 pilot and flame rod bracket, as shown in center of photo on Page 4.

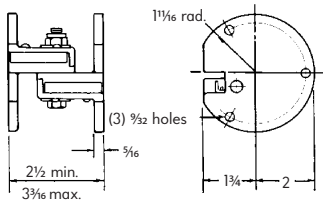

4-3159-1 Expansion Ignition Coupling

(wt. 3 1/4 lb)

Used in place of and far superior to the separator plate. It can telescope to absorb some expansion in an assembly when burners heat. It permits low fire side to pilot high fire side and vice versa.

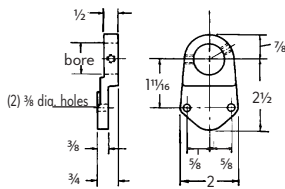

Pilot Bracket* (wt. 1 lb)

For mounting pilot tip only (no flame rod) as selected from table below. Use with Part No. 4-0804-2 as shown at rear of photo on page 4.

***Pilot Bracket Bore for Pilot Tip**

4-0680-1	1 1/64	4021-13, 4021-14,
4-0680-2	1 1/64	4021-15, 4021-16

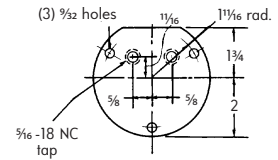

4-0804-2 Companion Endplate (wt. 1 lb)

For mounting pilot bracket, as shown at rear of photo on Page 4.

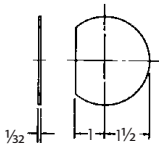

4-1739-1 Separator Plate (wt. 1/4 lb)

Used to separate mixer zones within an assembly. If all mixture pressures in an assembly are essentially equal, flame will cross separator plates so one pilot suffices for the entire assembly.

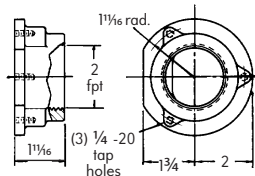

4-0803-1 2" Inlet Flange (wt. 2 lb)

Bolted to the end of any section, it provides a threaded 2" pipe size feed connection.

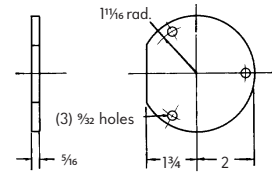

4-0804-1 Std. Endplate (wt. 1 lb)

Used to close ends of an assembly.

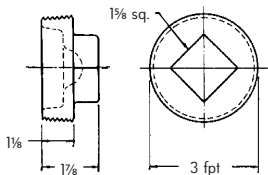

**3" Pipe Plug
Std. Sq. Hd** (wt. 3 1/4 lb)

For plugging unused feed connections.

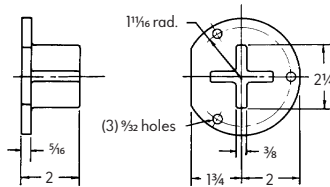

4-0827-1 Supporting Endplate

(wt. 1 3/4 lb)

In addition to closing the end of an assembly, it provides a 2" projection for supporting the assembly (see rear of photo on Page 4).

4630HK Hardware Kit (wt. 1/4 lb)

Used to connect sections and accessories. Three fasteners per kit; one kit per connection. Hardware Kit consists of three hex head bolts (1/4 -20 UNC by 1 1/4" lg.) and three hex nuts (1/4").

Hardware is included with each main burner section.

IGNITION

Three ignition arrangements are available:
(For oven applications consult NFPA 86.)

4630-P: for direct spark ignition with provision for flame detector,

4-2408-3 Pilot and Flame rod Bracket: for 4021-15 or 4021-16 Pilot Tip plus flame rod,

4-0680-1 or 4-0680-2 Pilot Bracket: Pilot tip only (when remote flame detector is used).

FEATURES

If blower supplies sufficient air through burners for complete combustion, reGen® Burners operate dependably in an inert atmosphere. Burners have machined ends, permitting assembly of various configurations without gaskets.

Stainless steel flame retention strips, which give the burner its stability in high velocity air streams, are fastened so they prevent combustion between the strip and casting, resulting in lower strip and casting temperatures to prolong burner life.

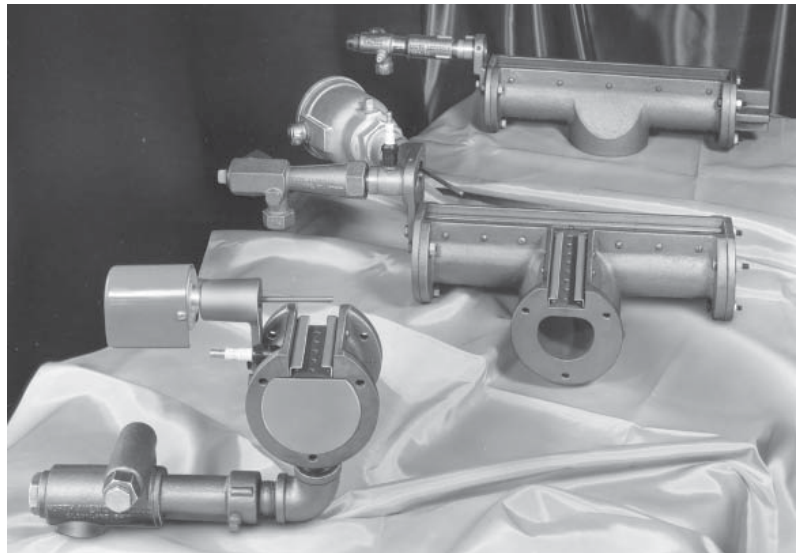

Pictured from front to rear are a 4630-P Pilot Section, 4630-T Tee with 3" bottom inlet, and 4630-B 12" straight with 3" bottom inlet, all displaying various types of ignition and flame detection.

INSTALLATION

reGen Burner assemblies can be used with inspirators, but aspirator mixers are preferred for good turndown and air/fuel ratio control.

Burners can be operated at mixture pressures from 0.35 to 12"wc, giving 6:1 turndown.

4630 Burner sections are shipped unassembled. No gaskets are used. Be sure to order all appropriate accessories, including flanges, endplates, separator plates, and hardware kits.

When they get hot, line burner assemblies expand unevenly and tend to bow in the center. Short assemblies can be bolted down securely, and flanges will take up the expansion.

For longer lengths with no bottom feed connections (or one bottom feed only at the center), support assembly rigidly at its center, leaving ends free to bow away. When two or more bottom feed connections are used in an assembly, install 4-3159-1 Expansion Ignition Couplings between the bottom inlets.

To order specify: 4630-(appropriate letter)-(capacity rating‡) section description, and 4630HK hardware kits to connect sections.

‡ From Table I at 4"wc mixture pressure (eliminate "000").

Example: 4630-T-119 Tee

Burner section designation	quantity	replacement retention strips (with screws)			
		flame retention strips part no.	description	strip mounting screws quantity/section	part no.
4630-B, -E, -H	2	4-3086-1		10	R777-0250-SX
4630-L	{ 1	4-3137-1	inside angle	8	R777-0250-SX
		4-3137-2	outside angle		
4630-N	2	4-3128-1		8	R777-0250-SX
4630-P	{ 1	4-3161-1	on spark plug side	4	R777-0250-SX
		4-3139-1	opposite spark plug		
4630-S Ign. Cplg.	2	4-3139-1		4	R777-0250-SX
	2	4-3139-1		4	R777-0250-SX
4630-T	{ 1	4-3086-1	straight	17	R777-0250-SX
		4-3114-1	angle		
4630-X	4	4-3114-1		24	R777-0250-SX

WARNING: Situations dangerous to personnel and property may exist with the operation and maintenance of any combustion equipment. The presence of fuels, oxidants, hot and cold combustion products, hot surfaces, electrical power in control and ignition circuits, etc., are inherent with any combustion application. Parts of this product may exceed 160F in operation and present a contact hazard. Fives North American Combustion, Inc. urges compliance with National Safety Standards and Insurance Underwriters' recommendations, and care in operation.