



IGNITION TRANSFORMERS

For UL classification, minimum secondary voltage for pilot ignition transformers is 6000 volts. All units listed below at 6000 volts or above meet this requirement. 6000 volt transformers are adequate for Fives North American ignition systems using 10mm automotive type spark plugs in a pilot tip or burner. Larger center electrode igniters generally require 10 000 volt transformers, such as the 4065-6N1-10A. All units are rated for constant or intermittent duty.

All standard 6000 volt transformers listed below have a junction compartment for the primary splice and a recessed

high voltage terminal to minimize the hazard of accidental shocks. The 4065-6N1-10A (10 000 volt) transformer has a screw-type high voltage terminal and requires a 4085XX-B ignition cable with a 1/4" ring connector. A 12 x 12 enclosure is needed. The high temperature versions, 4065HT-, have wire leads for primary connection.

Transformer cases **must** be grounded to burner bodies through a metallic connection.

Transformer Designation	PRIMARY			SECONDARY		No. of secondary terminals	Weight, lb	4085 Ignition cable req'd. (style)	Enclosure
	volts	hertz	VA	volts	mA				
4065-5N1-6A	120	50	180	6 000	20	1	10	Standard	None
4065-5N4-6A	120	50	180	6 000	20	1	10	Standard	10 x 8 NEMA 4
4065-6N1-10A	120	60	250	10 000	22	1	25	-B	None
4065-6N1-5B	120	60	250	5 000	22	2	15	-A	None
4065-6N1-5D	120	60	500	5 000	22	4	15	-A	None
4065-6N1-6A	120	60	180	6 000	20	1	10	Standard	None
4065-6N4-10A	120	60	250	10 000	22	1	25	-B	12 x 12 NEMA 4
4065-6N4-6A	120	60	180	6 000	20	1	10	Standard	10 x 8 NEMA 4
4065-6N4X-6A	120	60	180	6 000	20	1	10	Standard	10 x 8 NEMA 4X SST
4065-6N7-6A	120	60	180	6 000	20	1	30	Standard	NEMA 7
4065-6N4XF-6A	120	60	180	6 000	20	1	10	Standard	NEMA 4X Fiberglass
4066-5N1-6A	240	50	180	6 000	20	1	10	Standard	None
4066-5N1-12A	230	50	300	12 000	22	1	15	-A	None
4066-5N1-12B	240	50	250	12 000	22	2	17	-A	None
4066-5N4-6A	240	50	180	6 000	20	1	10	Standard	NEMA 4
4066-5N4-12A	230	50	300	12 000	22	1	15	-A	NEMA 4
4066-6N1-6A	240	60	180	6 000	20	1	10	Standard	None
4066-6N4-6A	240	60	180	6 000	20	1	10	Standard	NEMA 4
4066-6N1-5B	240	60	250	5 000	22	2	15	-A	None

DIMENSIONS

inches

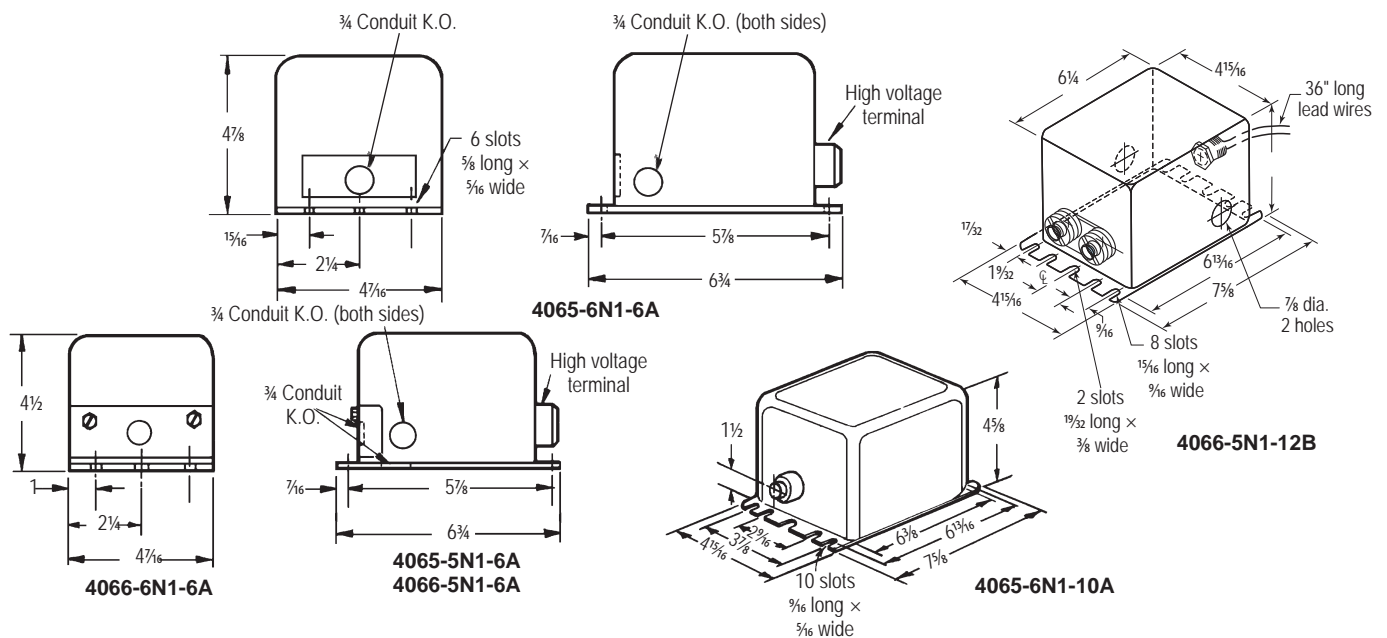

Some 4065 and 4066 Ignition Transformers are available with NEMA 4 weatherproof and NEMA 7 explosion proof enclosures. A standard 6 kV transformer is bolted to the bottom of an 8 × 10 × 6 enclosure appropriate for the rating, and a 10 kV transformer is bolted to the bottom of a 12 × 12 enclosure appropriate for the rating. A gasketed strain relief connector in one end of the enclosure permits running a standard 4085 Ignition Cable in to the transformer. See table for complete listing of available options.

DIMENSIONS inches

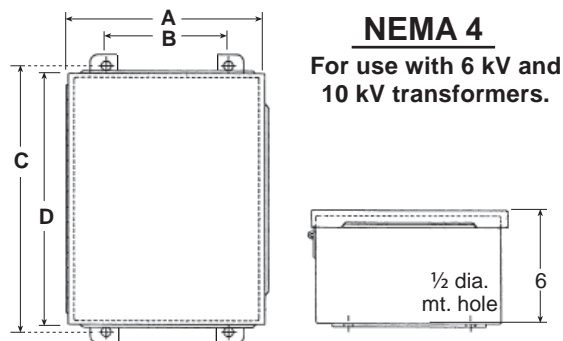

NEMA 4
For use with 6 kV and 10 kV transformers.

Approximate weight: 20 lb

Transformer	A	B	C	D
6 kV	8	5 ⁷ / ₁₆	10 ³ / ₄	10
10 kV*	12	9 ⁷ / ₁₆	12 ³ / ₄	12

*10 kV transformers require a 12 × 12 enclosure.

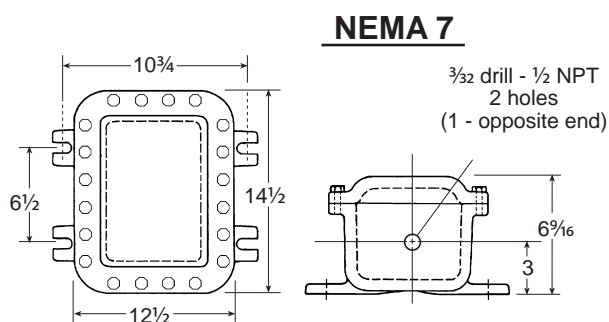

NEMA 7

Approximate weight: 40 lb

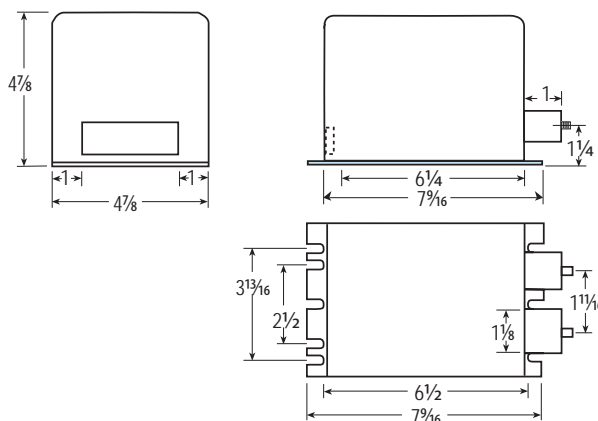

4065-6N1-5B

ORDERING INFORMATION

40 - N -

65 = 120 V Primary
66 = 240 V Primary

6 = 60 Hz Primary
5 = 50 Hz Primary

A = 1 Pole
B = 2 Pole
D = 4 Pole

5 = 5000 V Secondary
6 = 6000 V Secondary
10 = 10000 V Secondary

N1 = No Enclosure **N7** = NEMA 7 Enclosure
N4 = NEMA 4 Enclosure **N4X** = NEMA 4X Enclosure

DIMENSIONS SHOWN ARE SUBJECT TO CHANGE. PLEASE OBTAIN CERTIFIED PRINTS FROM FIVES NORTH AMERICAN COMBUSTION, INC.
IF SPACE LIMITATIONS OR OTHER CONSIDERATIONS MAKE EXACT DIMENSION(S) CRITICAL.

WARNING: Situations dangerous to personnel and property may exist with the operation and maintenance of any combustion equipment. The presence of fuels, oxidants, hot and cold combustion products, hot surfaces, electrical power in control and ignition circuits, etc., are inherent with any combustion application. Parts of this product may exceed 160F in operation and present a contact hazard. Fives North American Combustion, Inc. urges compliance with National Safety Standards and Insurance Underwriters recommendations, and care in operation.

Fives North American Combustion, Inc., 4455 East 71st Street, Cleveland, OH 44105 USA, Phone 216.271.6000
Fax 216.641.7852 email: fna.sales@fivesgroup.com • www.fivesgroup.com/fivesna