

North American Pilot Accessories Regulators, Solenoid Valves

Supplement 4015-1

Ref: Bulletins 4015, 4065; Sheet 4085

Atmospheric Pilot Regulators

"Zero gas" pilot systems require an atmospheric regulator to supply gas at zero gauge pressure to the pilot mixer. The 7350- -A is suitable for single pilot installations, or for several pilot tips manifolded off a common mixer, provided its capacity is not exceeded. For more tips use a 7218 Regulator, -1 or larger.

If inlet gas pressure exceeds 1 psi to the 7350- -A or 2 psi to the 7218, use a pressure-reducing regulator upstream. 7344 Regulators reduce up to 25 psi gas to 4-12"wc--see page 2.

For capacities or inlet pressures beyond the range of 7344 Regulators, see Bulletins 7337 and 7349.

7350- -A and 7350

Maximum recommended capacity is 303 scfh for the 1/2" regulators and 274 scfh for the 3/8" regulators. These capacities occur at 2.5"wc pressure drop.

Maximum Inlet Pressure: 7350- -A: 1 psit, 7350: 5 psi

Outlet Pressure Range: 7350- -A: -1.5"wc to 1"wc,
7350: 3"wc to 6"wc

Gases: Natural, LP, LP gas-air

Minimum Ambient Temperature: -40 F

Maximum Ambient Temperature: 200 F

Maximum Emergency Inlet Pressure: 7350- -A: 2 psit,
7350: 12.5 psi

Installation Position: No limitation

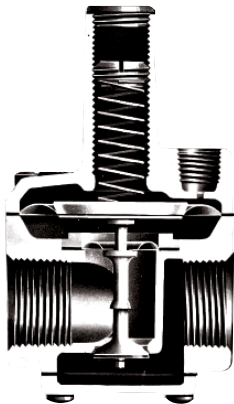

Capacity, scfh of 0.6 gravity gas	pres. drop across regulator, "wc		
	0.1	0.2	0.3
7350-02-A	54	77	95
7350-01-A	60	85	105
7350-02	54	77	95
7350-01	60	85	105

designation	dimensions, inches					swing radius	approx. wt, lb
	A	B	C	D	E		
7350-02, -02-A	3/8	2	2	1 5/16	3 9/16	2 5/8	1/2
7350-01, -01-A	1/2	2	2	1 5/16	3 9/16	2 5/8	1/2

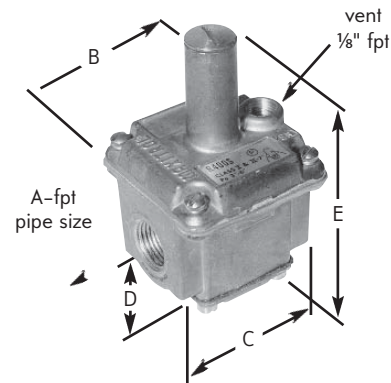

†If cross-connected to 16 psi air pressure, inlet pressure could go as high as 2 psi, depending on flow required.

7218

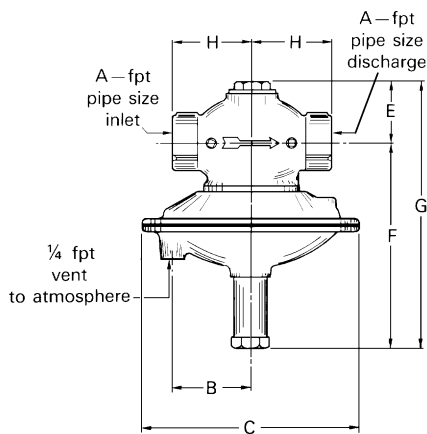

Maximum Inlet Pressure: 2 psi
Outlet Pressure (bias) Range: -1.7"wc to +0.2"wc
Gases: Natural, LP, LP gas-air
Maximum Ambient Temperature: 180 F
Maximum Shock Load: 5 psi
Installation Position: horizontal run of pipe only, with diaphragm below pipe

Regulator designation	dimensions in inches							wt, lb
	A	B	C	E	F	G	H	
7218-0	3/4	3 3/4	7 1/2	2 1/4	6 7/8	9 3/8	2 1/2	7.5
7218-1	1	3 3/4	7 1/2	2 1/16	6 7/8	9 5/16	2 3/4	8

pressure drop across regulator, osi	capacity, scfh of 0.6 gravity gas									
	1	2	2.5	3	4	6	8	10	12	
7218-0	381	540	603	661	763	935	1080	1207	1322	
7218-1	494	700	782	857	989	1212	1400	1565	1714	

Gas Gravity Correction Factors--For a gas gravity different from 0.6 multiply the regulator capacity by the appropriate gravity factor.

gas gravity	0.4	0.6	0.8	1.5	2.0
gravity factor	1.22	1.00	0.868	0.632	0.547

Pressure-Reducing Regulators

7344-01 and -1

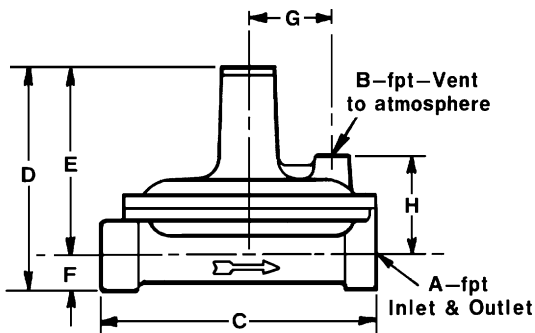

Maximum Inlet Pressure: 10 psi
Outlet Pressure Range: 4"wc to 12"wc
Gases: Natural, LP, LP gas-air
Maximum Ambient Temperature: 200 F
Maximum Emergency Inlet Pressure: 65 psi
Installation Position: Any position

Regulator designation	dimensions in inches								wt, lb
	A	B	C	D	E	F	G	H	
7344-01	1/2	1/8	4 1/8	3 1/2	2 7/8	5/8	1 1/4	1 1/2	3/4
7344-1	1	3/8	5 7/8	5 1/4	4 5/16	1 5/16	1 3/4	2 1/2	1 1/2

CAPACITIES, scfh of 0.6 gravity gas

outlet pressure, "wc	7344-01 inlet pressure, psi					7344-1 inlet pressure, psi				
	0.5	1	2	5	10	0.5	1	2	5	10
4.0	180	273	384	428	360	400	495	560	674	660
6.0	155	243	310	392	340	300	420	550	625	620
8.0	122	212	263	310	288	200	300	395	500	480

Gas Gravity Correction Factors--For a gas gravity different from 0.6 multiply the regulator capacity by the appropriate gravity factor.

gas gravity	0.4	0.6	0.8	1.5	2.0
gravity factor	1.22	1.00	0.868	0.632	0.547

SOLENOID VALVES
1486A-02, -01, and 1486A-0

UL listed and FM approved as main gas safety shutoff valves (see note) two-way, normally closed, general purpose and watertight enclosure for manufactured, natural or propane gas 120/60/110/50 standard (must be installed with solenoid vertical and upright)

NOTE: Valves comply with NFPA standards for systems up to 150,000 Btu/hr. Systems above 150,000 Btu/hr require position indicating valve(s) such as the 1486F, 1411, 1412, 1518/19, 1520.]

Valve designation	pipe size	maximum pressure psig	capacity, cfh 0.6 sp gr gas 1"wc ΔP (2"wc inlet)	coil			body material
				class	holding	VA inrush	
1486A-02	3/8"	100	40	F	40	70	brass
1486A-01	1/2"	50	240	F	25	70	aluminum
1486A-0	3/4"	50	250	F	25	70	aluminum

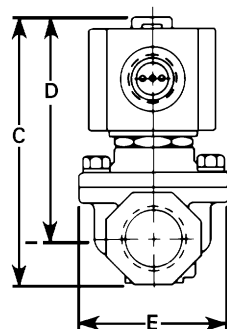
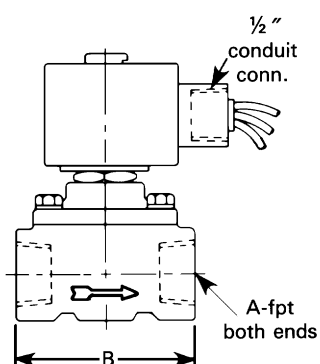

Solenoid Gas Valves (Type 2, 3, 3S, 4, and 4X)

Valve designation	dimensions in inches					wt, lb
	A	B	C	D	E	
1486A-02	3/8	1 7/8	3 1/4	2 11/16	1 5/16	1 3/8
1486A-01	1/2	2 3/4	4 1/32	3 15/32	2 11/32	1 3/4
1486A-0	3/4	3 5/16	4 15/32	3 21/32	2 11/32	1 13/16

DIMENSIONS SHOWN ARE SUBJECT TO CHANGE. PLEASE OBTAIN CERTIFIED PRINTS FROM FIVES NORTH AMERICAN COMBUSTION, INC. IF SPACE LIMITATIONS OR OTHER CONSIDERATIONS MAKE EXACT DIMENSION(S) CRITICAL.

WARNING: Situations dangerous to personnel and property may exist with the operation and maintenance of any combustion equipment. The presence of fuels, oxidants, hot and cold combustion products, hot surfaces, electrical power in control and ignition circuits, etc., are inherent with any combustion application. Parts of this product may exceed 160F in operation and present a contact hazard. Fives North American Combustion, Inc. urges compliance with National Safety Standards and Insurance Underwriters' recommendations, and care in operation.



CONTACT US:
Fives North American Combustion, Inc.
4455 East 71st Street - Cleveland, OH 44105 - USA
Tel: +1 216 271 6000 - Fax: +1 216 373 4237
Email: fna.sales@fivesgroup.com

www.fivesgroup.com