

# North American 2300 and 2400 Turbo Blowers

Instructions and Felt Seal List 2300/2400

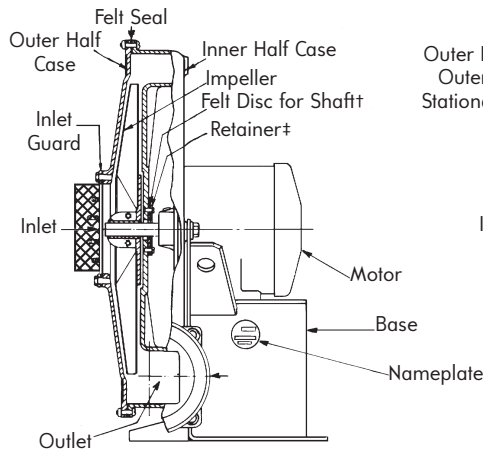

**2300 and 2400 Direct Drive Single Stage**

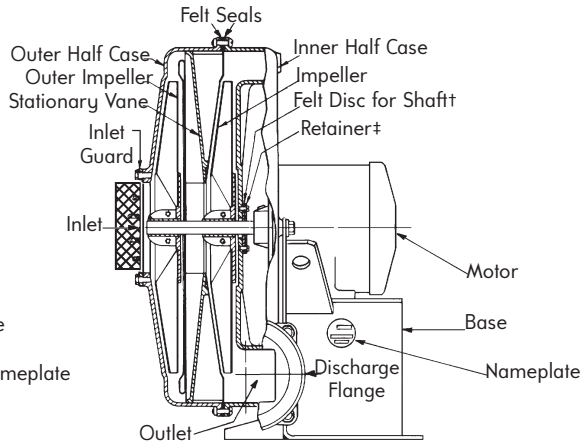

**2300 Direct Drive Multi-Stage**

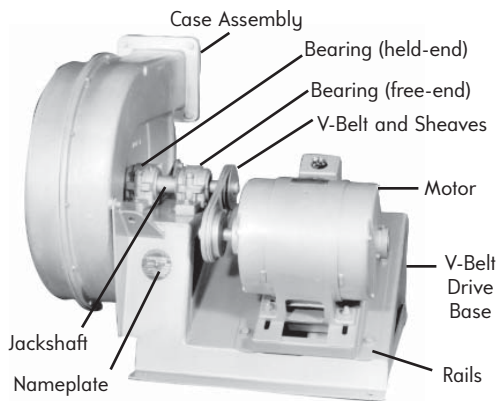

**2300 V-Belt Drive**

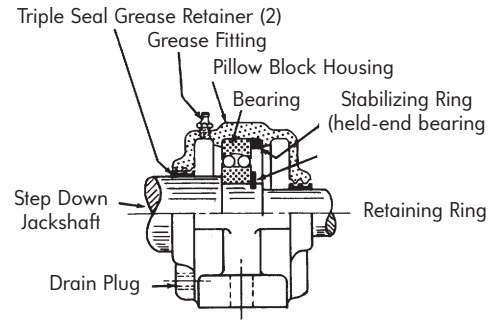
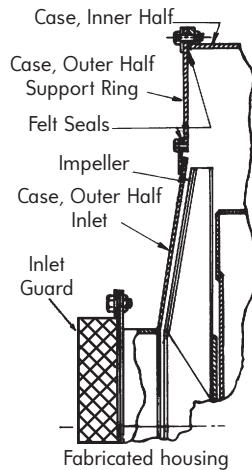

Pillow block & bearing detail

**NOTE:** "Held-end" bearing on V-belt blower is next to case assembly. On coupled-drive blowers it is next to flexible coupling. No stabilizing ring required on "free-end" bearing.

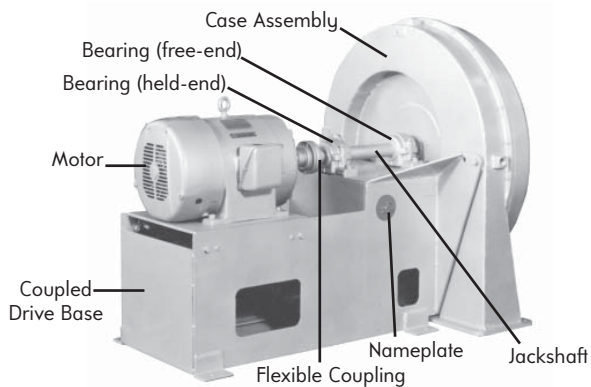

**2300 Coupled Drive**

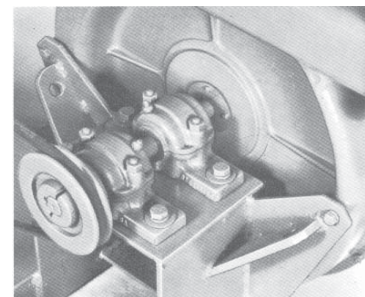

Close-up view of pillow blocks

†Except 2400 Series.

‡Except 2400D and F.

**Parts Order Must Specify:** ① — Blower Designation    ② — S. O. Number    ③ — Part Name

Standard guards are omitted from photos to give a better view of parts. All guards must be in place when blowers are being used.

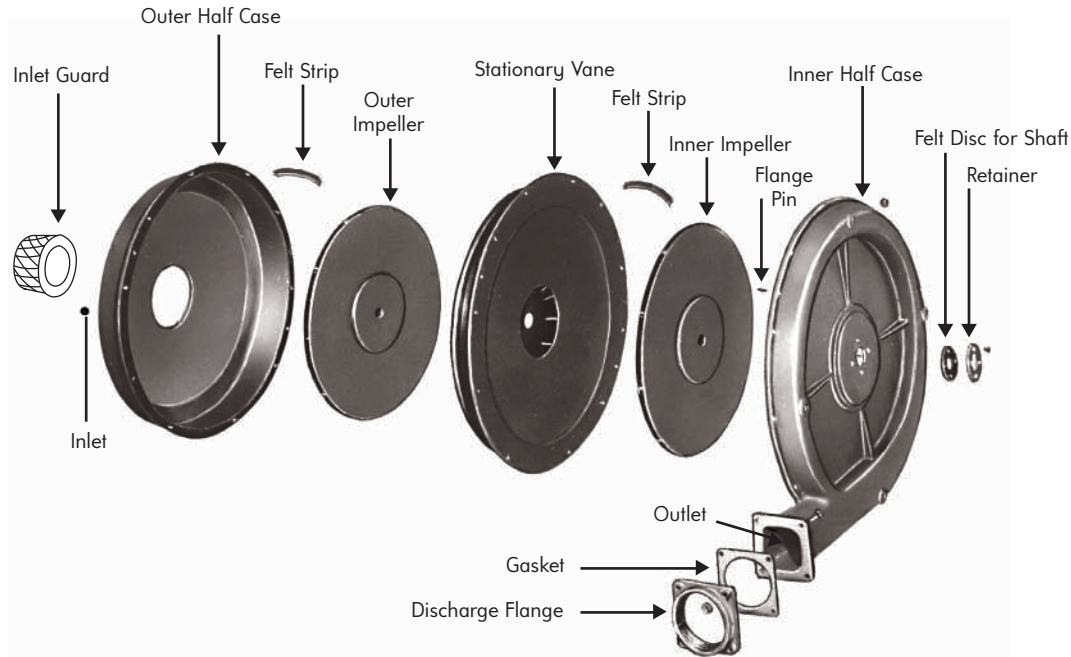

Exploded view of a turbo blower case assembly. For single stage blowers, there is no stationary vane and only one impeller.

## SERVICING

Case assemblies are identical for direct connected, V-belt, and coupled drive turbo blowers. A typical two-stage blower is shown. Single stage blowers use identical inner case and impeller but omit stationary vane and one impeller, and have a shallower outer case. Three-stage blowers use two stationary vanes, three impellers, and use a peripheral spacer between stationary vanes.

## INSTRUCTIONS FOR DISASSEMBLY

1. Remove intake guard.
2. Remove case flange bolts and nuts.
3. Remove outer case being careful not to bump impeller. (Felt seal should come off with outer case.)
4. Loosen impeller hub screws and remove impeller (and bushing, if any). **CAUTION: Impellers are accurately balanced and should be handled with care. Grasp impellers by hubs only.**
5. For multi-stage blowers, drive out the two case flange pins from the motor side to remove stationary vanes (these pins support vanes so they do not drop on the impeller). Felt seal should come off with stationary vanes, and pins should remain in the vanes.
6. Remove impeller as in Step 4.
7. If necessary to remove inner case, make note of location of each shim and spacer.
8. Remove motor if required.

## INSTRUCTIONS FOR ASSEMBLY

1. Mount inner case to base.
2. Mount motor to base but do not tighten bolts.
3. Mount inner impeller on motor shaft and line up motor so flat side of impeller is  $\frac{1}{8}$ " away from inner case all around. Tighten motor bolts.
4. Tighten impeller hub screws. Use torque table on page 4 for impeller hub screws only.
5. Mount stationary vanes with case flange pins and drive them snugly into inner case.
6. Mount impeller to shaft but do not tighten.
7. Mount outer case and bolt in place.
8. Slide impeller forward against inner side of outer case then back again  $\frac{1}{8}$ ". Tighten impeller hub screws. Use torque table on page 4 for impeller hub screws only.
9. Turn motor over several times by hand to check clearances.
10. Start motor and listen for clicking that would indicate misalignment of impellers. If this should occur, shut motor off immediately to prevent serious damage to impellers.
11. Check rotation of impellers according to arrow on case.
12. V-belt or coupled drive blowers must be checked after assembly for alignment of belts or couplings, to guard against excessive wear.

FELT SEAL CROSS-REFERENCE

Blower designation	Kit part number	Blower designation	Kit part number	Blower designation	Kit part number
2304-11/1-T.3D	1-4118-1	2316-14/2-T1.5D	1-4118-11	2320-35/1-T10D	1-4118-24
2308-11/3-T.5D	1-4118-18	2316-14/2-T1D	1-4118-10	2320-35/1-T15D	1-4118-25
2308-14/1-T.5D	1-4118-2	2316-17/2-T1.5D	1-4118-11	2320-41/1-T25D	1-4118-49
2308-14/1-T.75D	1-4118-2	2316-17/2-T2D	1-4118-11	2320-41/1-T30D	1-4118-49
2308-14/1-T1D	1-4118-2	2316-17/2-T3D	1-4118-13	2320-41/1-T60D	1-4118-50
2308-17/1-T1D	1-4118-2	2316-19/1-T1.5D	1-4118-44	2324-14/3-T1.5D	1-4118-22
2308-17/1-T1.5D	1-4118-3	2316-19/1-T2D	1-4118-44	2324-14/3-T2D	1-4118-22
2308-17/1-T2D	1-4118-3	2316-19/1-T3D	1-4118-45	2324-19/2-T3D	1-4118-17
2308-21/1-T10D	1-4118-31	2316-19/1-T5D	1-4118-45	2324-21/1-T20D	1-4118-36
2308-24/1-T2D	1-4118-5	2316-21/1-T15D	1-4118-25	2324-26/2-T5D	1-4118-19
2308-24/1-T3D	1-4118-6	2316-21/1-T20D	1-4118-25	2324-26/2-T7.5D	1-4118-20
2308-31/1-T5D	1-4118-26	2316-24/2-T2D	1-4118-14	2324-33/1-T25D	1-4118-28
2308-31/1-T7.5D	1-4118-27	2316-24/2-T3D	1-4118-15	2324-33/1-T30D	1-4118-28
2308-47/1-T50D	1-4118-46	2316-24/2-T5D	1-4118-15	2324-33/1-T40D	1-4118-29
2310-11/4-T.5D	1-4118-21	2316-26/1-T3D	1-4118-8	2324-33/1-T50D	1-4118-42
2310-19/1-T.75D	1-4118-4	2316-26/1-T5D	1-4118-8	2324-33/1-T60D	1-4118-43
2310-19/1-T1D	1-4118-4	2316-26/1-T7.5D	1-4118-9	2324-35/2-T10D	1-4118-37
2310-19/1-T1.5D	1-4118-5	2316-28/1-T5D	1-4118-30	2324-35/2-T15D	1-4118-38
2310-19/1-T2D	1-4118-5	2316-28/1-T7.5D	1-4118-31	2332-19/3-T3D	1-4118-23
2310-21/1-T10D	1-4118-31	2316-31/2-T7.5D	1-4118-33	2332-19/3-T5D	1-4118-23
2310-26/1-T3D	1-4118-8	2316-31/2-T10D	1-4118-34	2332-21/2-T20D	1-4118-38
2310-26/1-T5D	1-4118-8	2316-33/1-T25D	1-4118-28	2332-21/2-T25D	1-4118-39
2310-35/1-T7.5D	1-4118-31	2316-33/1-T30D	1-4118-28	2332-21/2-T30D	1-4118-39
2312-11/4-T.5D	1-4118-21	2316-35/1-T10D	1-4118-24	2332-21/2-T40D	1-4118-40
2312-19/1-T1.5D	1-4118-5	2316-35/1-T15D	1-4118-25	2332-28/2-T10D	1-4118-35
2312-19/1-T1D	1-4118-4	2316-41/1-T20D	1-4118-48	2332-28/2-T15D	1-4118-36
2312-19/1-T2D	1-4118-5	2316-41/1-T25D	1-4118-49	2332-28/2-T7.5D	1-4118-35
2312-21/1-T15D	1-4118-32	2316-41/1-T30D	1-4118-49	2332-33/2-T50D	1-4118-42
2312-26/1-T3D	1-4118-8	2320-19/2-T1.5D	1-4118-16	2332-33/2-T60D	1-4118-43
2312-26/1-T5D	1-4118-8	2320-19/2-T2D	1-4118-16	2344-21/2-T30D	1-4118-39
2312-26/1-T7.5D	1-4118-9	2320-19/2-T3D	1-4118-17	2344-21/2-T40D	1-4118-40
2312-35/1-T10D	1-4118-31	2320-21/1-T15D	1-4118-25	2344-21/2-T50D	1-4118-40
2312-35/1-T7.5D	1-4118-31	2320-21/1-T20D	1-4118-25	2344-28/3-T15D	1-4118-41
2312-47/1-T75D	1-4118-47	2320-26/2-T5D	1-4118-19	2344-28/3-T20D	1-4118-41
		2320-26/2-T7.5D	1-4118-20	2400-D	1-4118-52
		2320-33/1-T25D	1-4118-28	2400-F	1-4118-53
		2320-33/1-T30D	1-4118-28	2400-G	1-4118-54
		2320-33/1-T40D	1-4118-29		
		2320-33/1-T50D	1-4118-29		

NOTE 1: 2400 series D, F, and G do not require shaft seal.  
 NOTE 2: For 50 Hz blowers, please consult Fives  
 NOTE 3: Kit includes felt strip for housing and disc and retainer for shaft (where applicable).  
 NOTE 4: 2300 series 34, 37, and 39--for instructions and seals please consult Fives

## Torque Chart

General Bolt and Screw Connections					
Bolts				Socket Head Screw	
	(ft.-lb)	(ft.-lb)	(ft.-lb)		(in.-lb)
SIZE:	A307, or GRADE 2	A325, or GRADE 5	A574 SHC, or GRADE 8	SIZE:	
1/4"	2	6	9	#3-48	9
5/16"	5	13	18	#3-56	10
3/8"	10	23	33	#4-40	13
7/16"	15	40	52	#4-48	14
1/2"	20	65	95	#5-40	20
9/16"	40	95	135	#5-44	21
5/8"	55	130	185	#6-32	25
3/4"	100	230	325	#6-40	28
7/8"	165	370	500	#8-32	48
1"	250	560	800	#8-36	51
1-1/8"	350	810	1100	#10-24	70
1-1/4"	500	1120	1600	#10-32	76
1-3/8"	650	1500	2100		
1-1/2"	850	1940	2750	1/4-20	160
M10	10	25	35	1/4-28	180
M12	20	65	95	5/16-18	325
M14	40	95	135	5/16-24	360
M16	55	130	185		
M20	100	230	325		
M24	250	560	800		
M30	350	810	1100		
M36	650	1500	2100		

Torque values are for dry bolts. If the connection bolts are oil lubricated, use 90% of the torque values.

If they are coated with anti-seize, use 60% of the torque values.

**WARNING:** Situations dangerous to personnel and property may exist with the operation and maintenance of any combustion equipment. The presence of fuels, oxidants, hot and cold combustion products, hot surfaces, electrical power in control and ignition circuits, etc., is inherent with any combustion application. Parts of this product may exceed 160F in operation and present a contact hazard. Fives North American Combustion, Inc. urges compliance with National Safety Standards and Insurance Underwriters' recommendations, and care in operation.



**CONTACT US:**  
**Fives North American Combustion, Inc.**  
 4455 East 71st Street - Cleveland, OH 44105 - USA  
 Tel: +1 216 271 6000 - Fax: +1 216 373 4237  
 Email: fna.sales@fivesgroup.com

www.fivesgroup.com