

Pillard NANO_xFLAM[®] Compact

«All-in-One» ultra low NO_x burner range

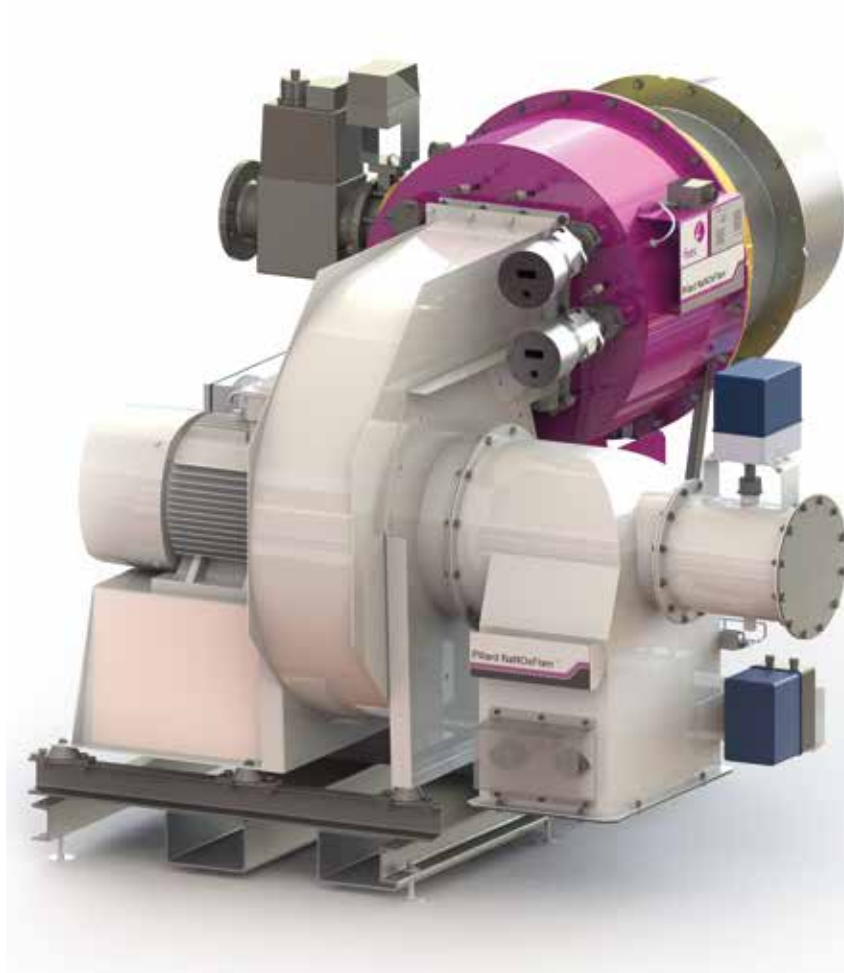

Ultimate NO_x
performance

Under 9 ppm @3% O₂

Best Available Technique that overcomes the limits of ultra low NO_x combustion now available in compact version

- Outstanding ultra-low NO_x Emissions and high thermal operation efficiency with monobloc burner
- Safe and reliable
- Flame dimensions designed to fit most combustion chambers
- “Plug & play” technology: Pre-wired and tested in our workshop
- Standard design to guarantee reduced commissioning time

Fives designs and supplies a complete portfolio of eco-friendly ultra low NOx burners

Fives and its advanced engineering team has developed the Pillard NANOxFLAM[®], a pioneering new generation of ultra low NOx gas burner, based on the worldwide patented Pillard BLUEMix[®] technology consisting in a low and uniform flame temperature which also guarantees low CO values and high-combustion efficiency.

Until now, proposed as Duobloc version, the Pillard NANOxFLAM[®] burner is now available in a compact version to fit all industrial requirements on fire tube and water tube boilers, in 3 standardized sizes.

In addition to their excellent environmental performance, Pillard NANOxFLAM[®] compact burners have been eco-designed in accordance with the Fives engineered sustainability[®] program. The burner's component materials are over 96% recyclable and is coated with water-soluble paints.



Pillard NANOxFLAM[®] already implemented in more than 100 boilers (fire, tubes, water tubes)

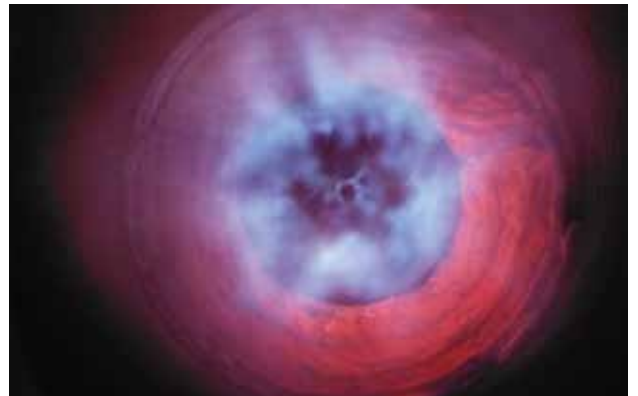

Pillard BLUEMix[®] technology

THE BEST PERFORMANCE AT YOUR SERVICE

PILLARD NANOxFLAM COMPACT BURNER MAIN FEATURES*

NOx emissions (with FGR)	< 9 ppm@3%O2dry (18mg/Nm3@3%O2dry)
CO emissions (with FGR)	< 10 ppm@3%O2dry (15mg/Nm3@3%O2dry)
Excess Air	≤ 15%
Turn Down	1 to 8
Combustion Air Operating Temperature	- 10 ≤ T (C°) + 60
Max FGR temperature	200°C
Max NG pressure (PS)	500 mb
Installation	Indoor, not tropicalised, non ATEX
Ambient temperature	-10 ≤ T (C°) + 40

* to be confirmed and adapted to your project

Fives European Combustion Centre: Innovation and R&D at your service



Fives is leading ongoing research and continual progress in combustion technology, introducing new solutions to meet increasingly stringent emission standards and provide relevant and efficient equipment. To accelerate innovation for the combustion market, Fives opened a new facility to support the company's R&D activities. With this new combustion centre, Fives reinforces its commitment to provide more efficient combustion systems, eco-friendly and offering best performances on the market.



- 3000 m²
- 30 MW installed test power – 4 test benches
- Firetube boiler, Water tube boiler
- Induct Furnace & Vertical Furnace
- Hot combustion air (300°C), FGR or TEG
- NG, FG, H₂, LPG, DO, biofuel
- Spray room
- CFD modeling (FLUENT®) applied to boilers, HRSG's, rotary kilns, Oil & Gas
- Flame video-monitoring by UV-high sensitive camera
- Remote monitoring system to enable test campaigns follow-up live from headquarters

EFFICIENT R&D POLICIES

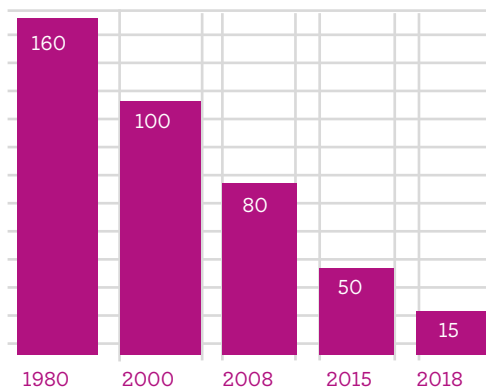

Pillard's Burner NO_x emission improvement since 1980 in mg/Nm³ 3%O₂dry in gas firing

- Over 100 Patents, with most of them as “Best Available Techniques”
- Over 20 years of improvement of burners NO_x emission

Pillard NANOxFLAM[®] compact overview

Pillard NANOxFLAM[®] compact burner is a “Plug & Play” (integrated BMS, FAN, gas skid, etc.), fully packaged, safe and reliable, ultra low NOx burner for the global energy industry.

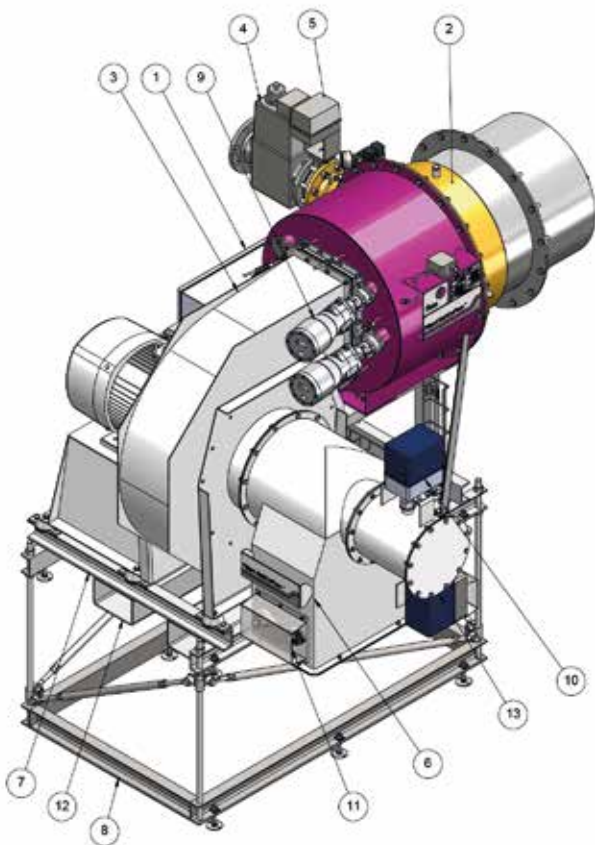

At-a-Glance by main applications and industries

- Small and Medium Firetube Boilers
- Small and Medium Water-tube Boilers
- Ultra low NOx Hot Gas Generator
- Urban Heating
- Process Heating
- Mirror design to fit double fire tube boilers

Mark	Description	Status
1	BMS Cabinet	Standard
2	Pillard NANOxFLAM [®]	Standard
3	Air & FGR FAN	Standard
4	Double Shut-Off Valves	Standard
5	Gas flow control Valve	Standard
6	Air & FGR Mixing Box	Standard
7	Upper Frame	Standard
8	Adjustable Lower Frame	Optional
9	Pillard Flame Check RUBY	Standard
10	FGR Control Damper	Optional
11	Air Control Damper	Standard
12	Forkliftable System	Standard

EEC COMPLIANCE / CERTIFICATES

- Best available technique as per BREF 2017
- 2006/42/EC (Machines)
- PED 2014/68/EC (Pressure)
- EN 676
- EN 298
- EN 746-2
- AQUAP 2007/01 (72h)
- C2E Marking

Pillard NANOxFLAM® compact overview

MAIN SCOPE AND OPTIONS

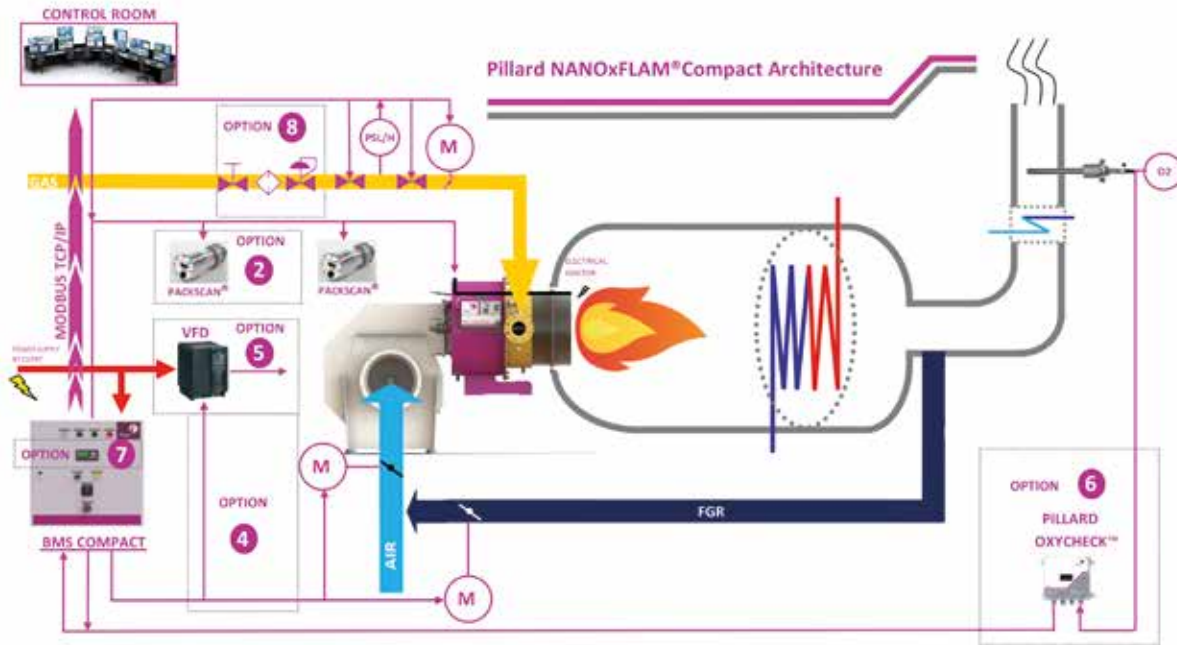

Mark	Description	Status
Option 1	Adjustable Frame	To adapt our burner to your combustion chamber axis
Option 2	2nd flame scanner	For a higher availability
Option 3	Spreader frame	To move the burner without a forklift
Option 4	VFD Compatible	BMS implemented for a VFD
Option 5	VFD	IP31 delivered loose
Option 6	O ₂ probe + transmitter	Pillard Oxycheck™ type
Option 7	Touchscreen HMI	7" touchscreen
Option 8	Gas Pressure reducer	Compact gas skid with manual isolating valve, gas filter and gas pressure reducer

LIFTING PRINCIPLES

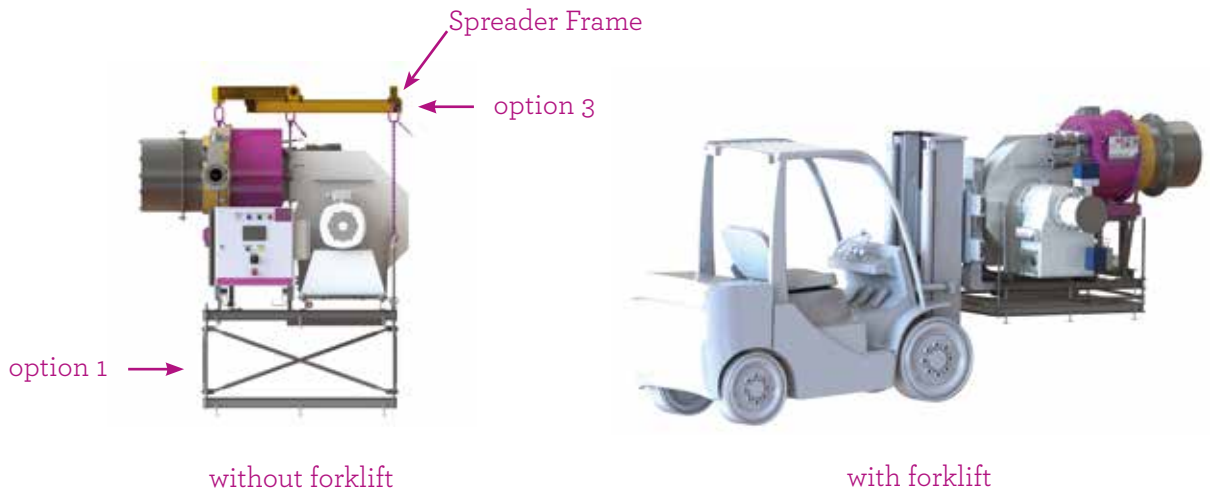

Pillard NANOxFLAM® Compact - N°1

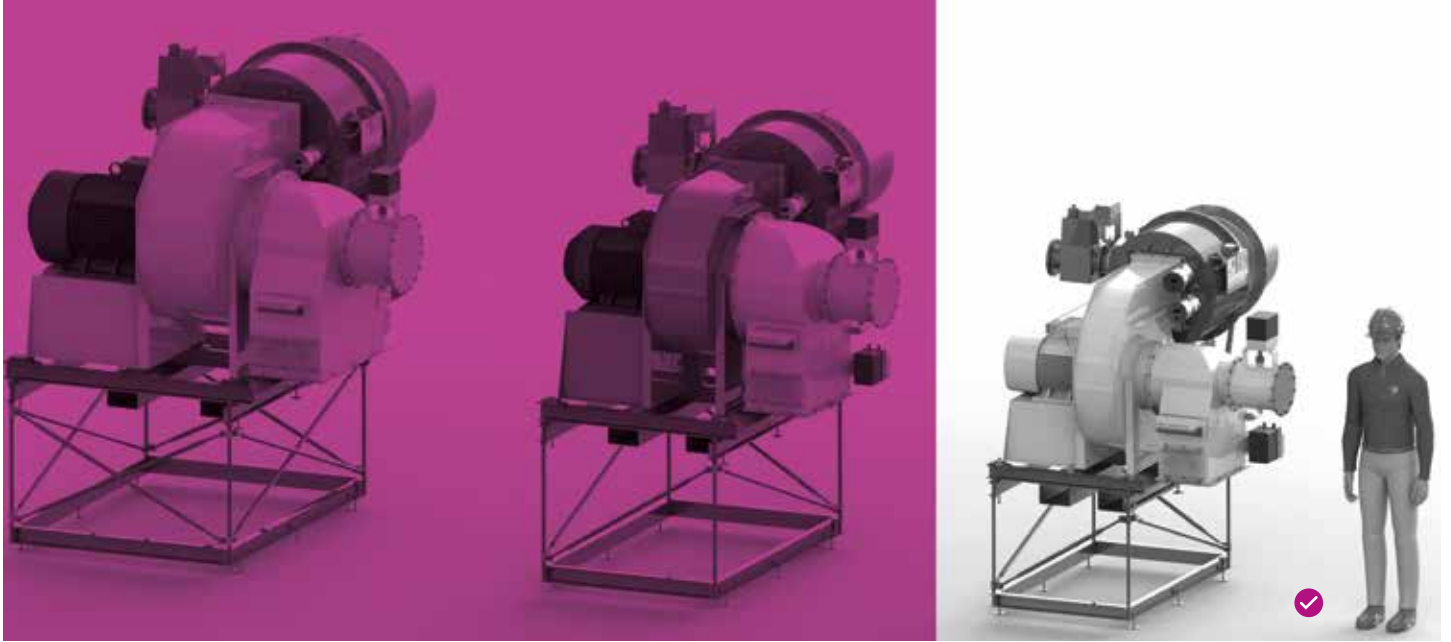

Key Features

Nominal heat output	from 6 to 8,4 MW ⁽¹⁾
Max. Turn Down ratio	1 : 8
Total Weight	980 kg
FAN motor	22kW ⁽²⁾
Gas Inlet (PN16)	4"

SELECTION CURVES

Compact n°1

Curves given for 20°C combustion air and 150°C FGR temperature.

⁽¹⁾ Select nominal burner load vs boiler back pressure and % FGR.

⁽²⁾ 30 kW (optional) to maintain nominal burner load over 250 mmWC boiler back pressure.

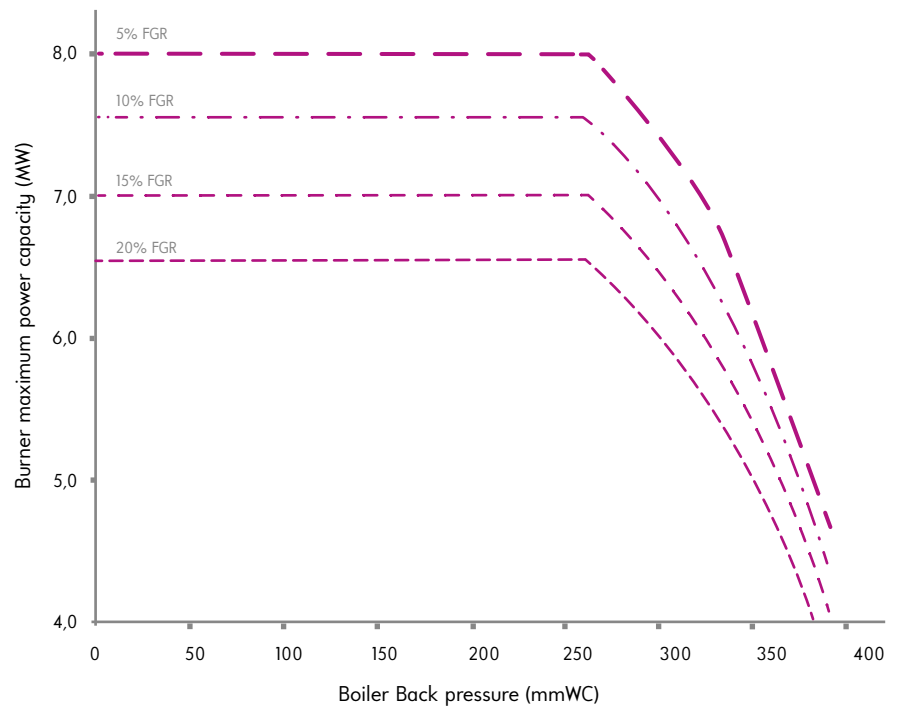

Overall Dimensions

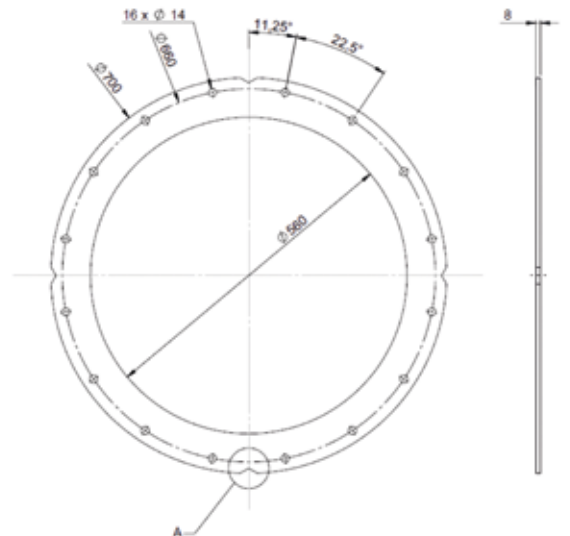
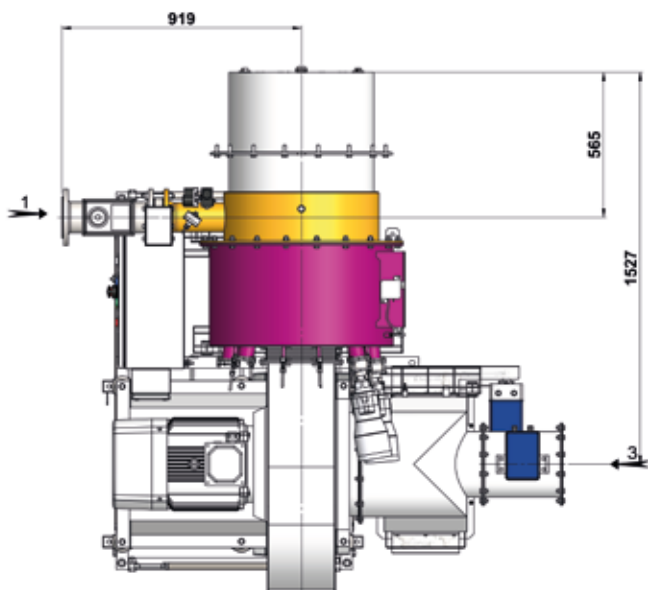
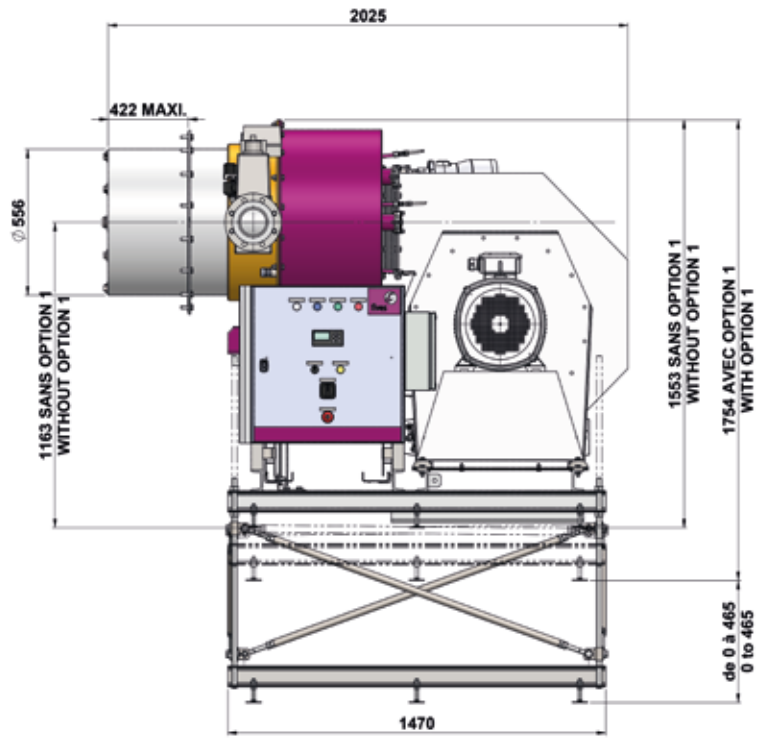
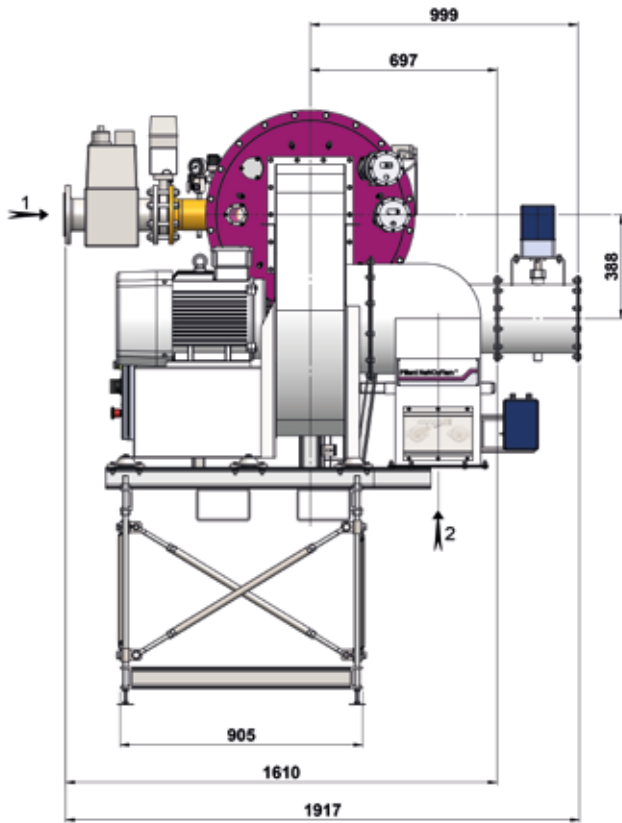

PIPING CONNECTIONS BOARD			
N°	FLUID	FLOW DIRECTION	DIMENSION N°1
1	NATURAL GAS	INLET	DN 100
2	COMBUSTION AIR	INLET	520 x 312
3	FGR	INLET	ID 250

Pillard NANOxFLAM® Compact - N°2

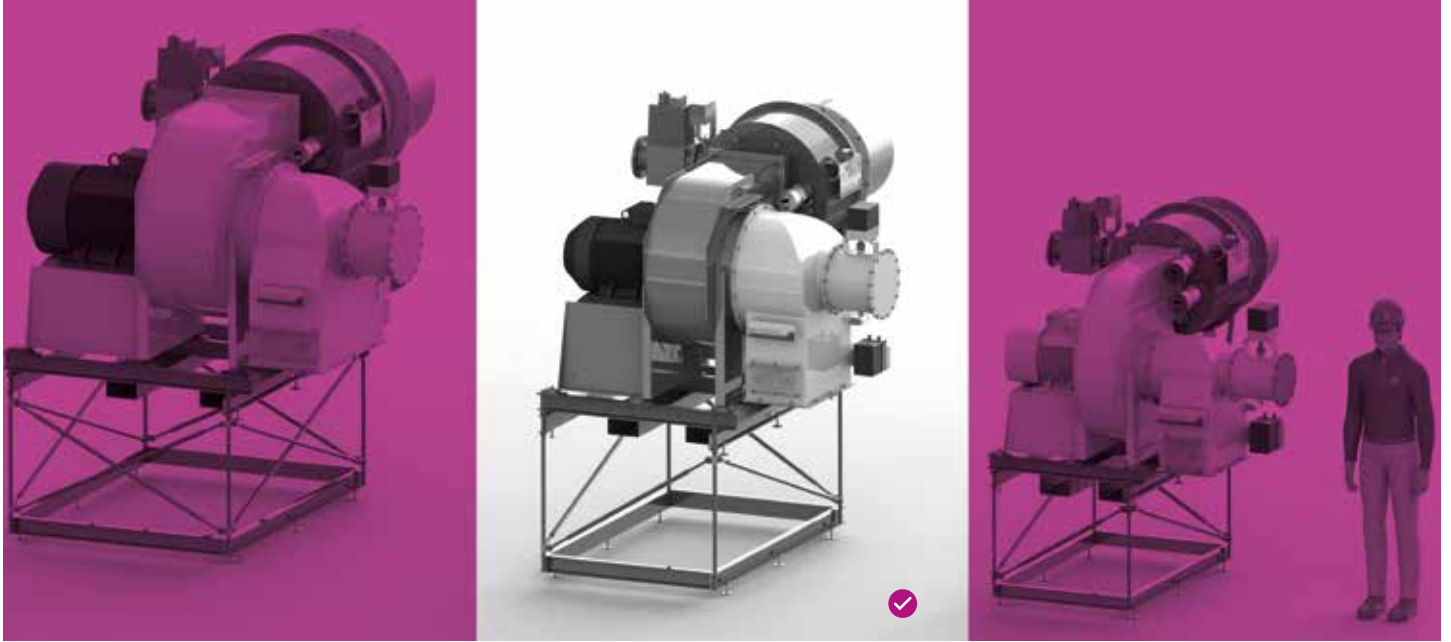

Key Features

Nominal heat output	from 8,4 to 12,7 MW ⁽¹⁾
Max. Turn Down ratio	1 : 8
Total Weight	1173 kg
FAN motor	45kW
Gas Inlet (PN16)	5"

SELECTION CURVES

Compact n°2

Curves given for 20°C combustion air and 150°C FGR temperature.

⁽¹⁾ Select nominal burner load vs boiler back pressure and % FGR.

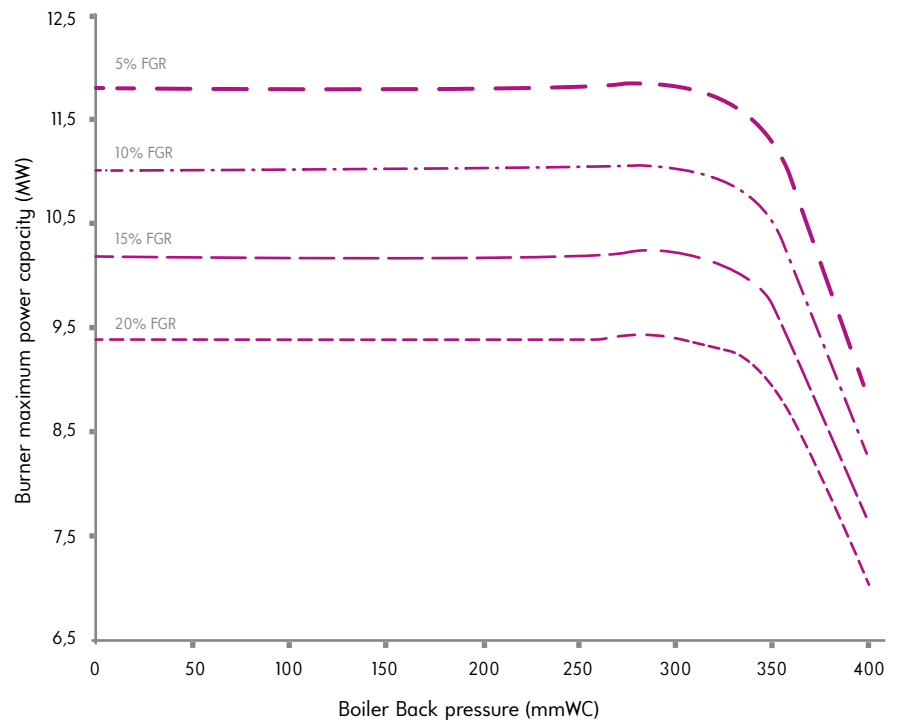

Overall Dimensions

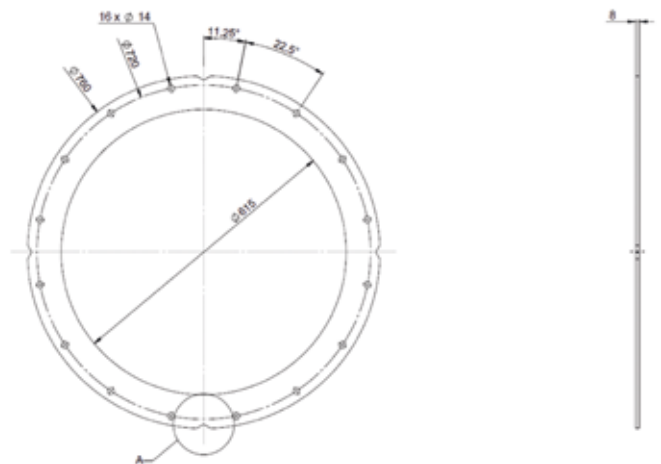
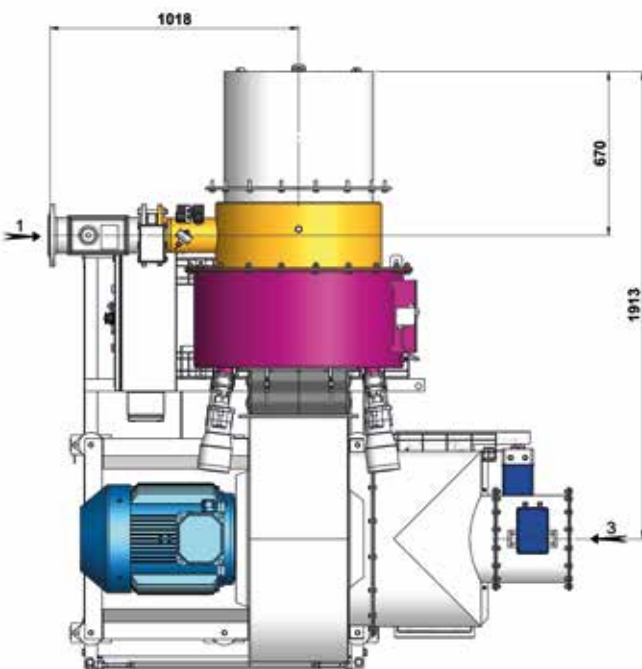
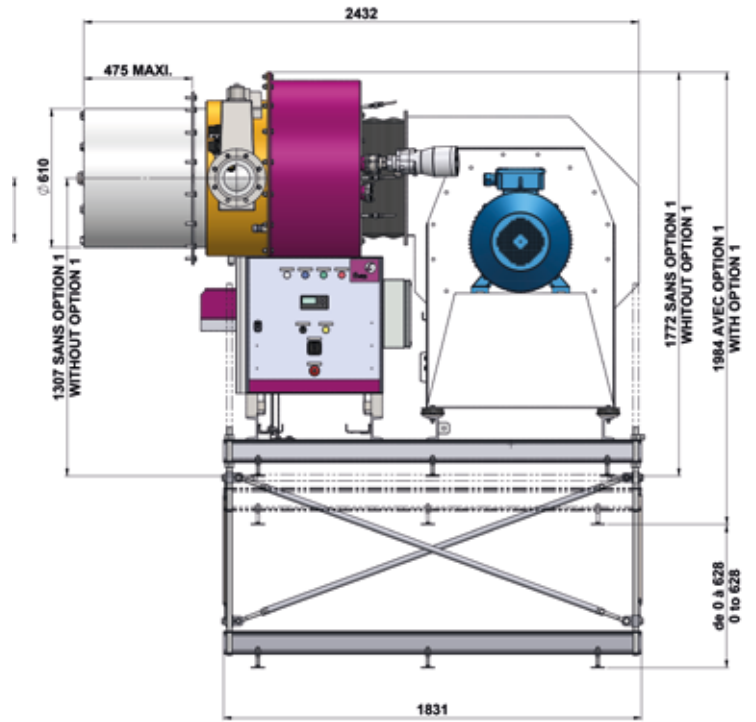
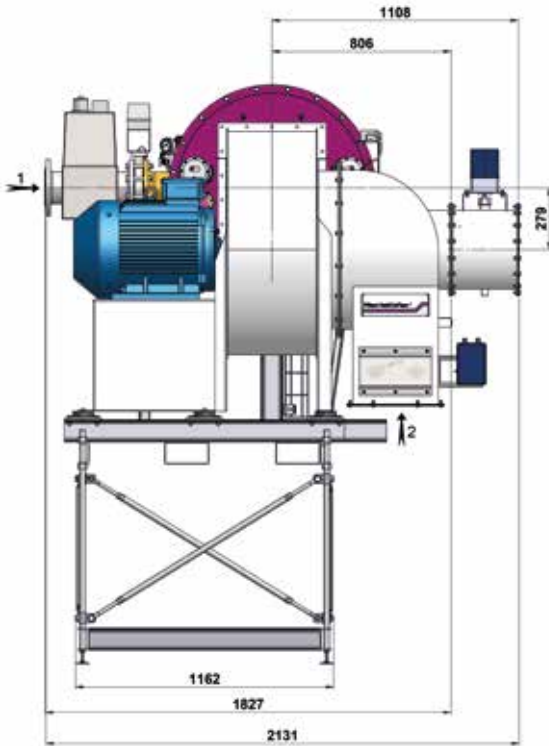

PIPING CONNECTIONS BOARD			
N°	FLUID	FLOW DIRECTION	DIMENSION N°2
1	NATURAL GAS	INLET	DN 125
2	COMBUSTION AIR	INLET	630 X 378
3	FGR	INLET	ID 350

Pillard NANOxFLAM® Compact - N°3

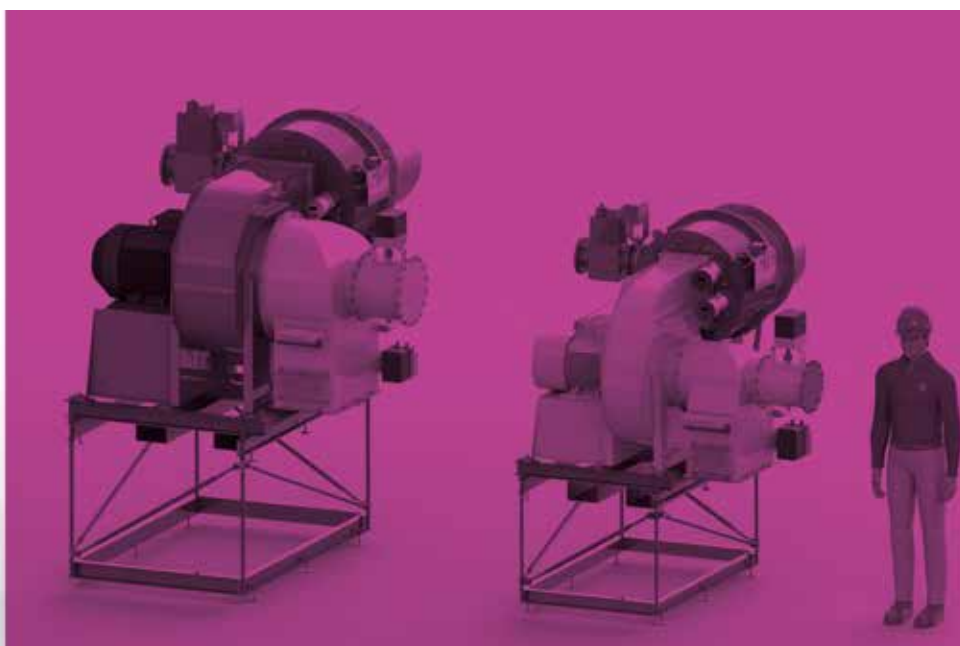

Key Features

Nominal heat output	from 14,8 to 21,6 MW ⁽¹⁾
Max. Turn Down ratio	1 : 8
Total Weight	1680 kg
FAN motor	70 kW ⁽²⁾
Gas Inlet (PN16)	5"

SELECTION CURVES

Compact n°3

Curves given for 20°C combustion air and 150°C FGR temperature.

⁽¹⁾ Select nominal burner load vs boiler back pressure and % FGR.

⁽²⁾ 90 kW (optional) to maintain nominal burner load over 250 mmWC boiler back pressure.

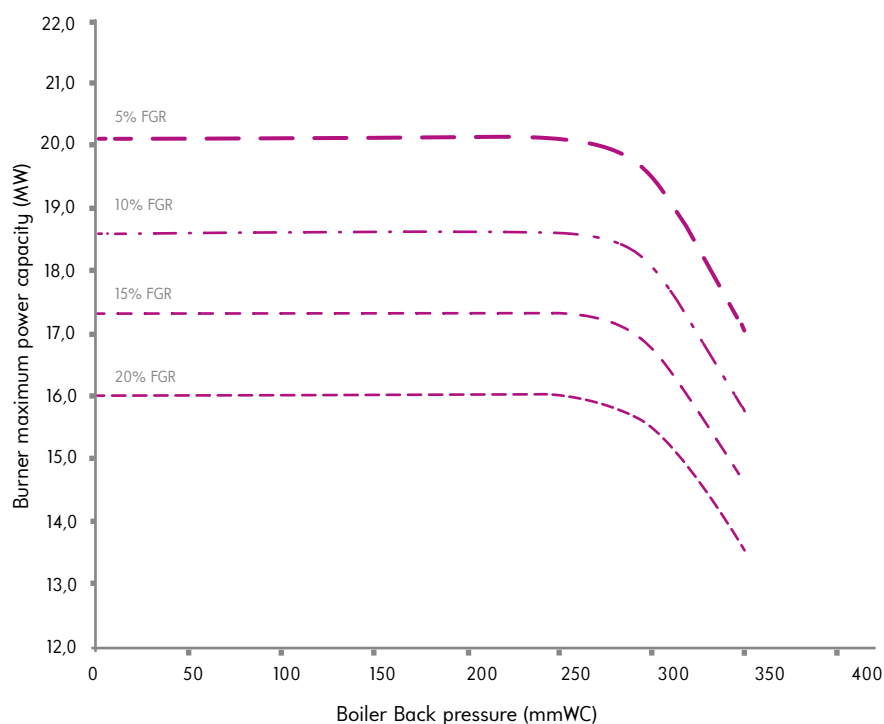

Overall Dimensions

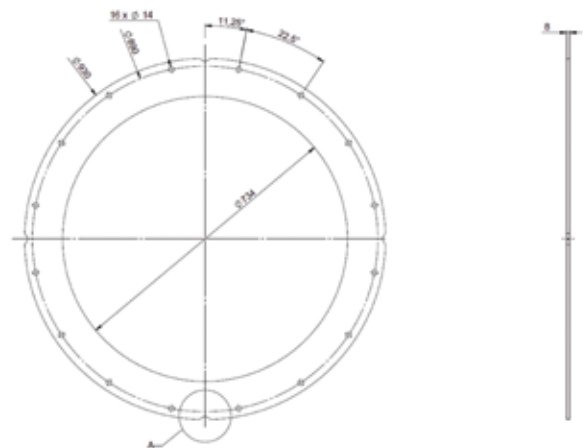
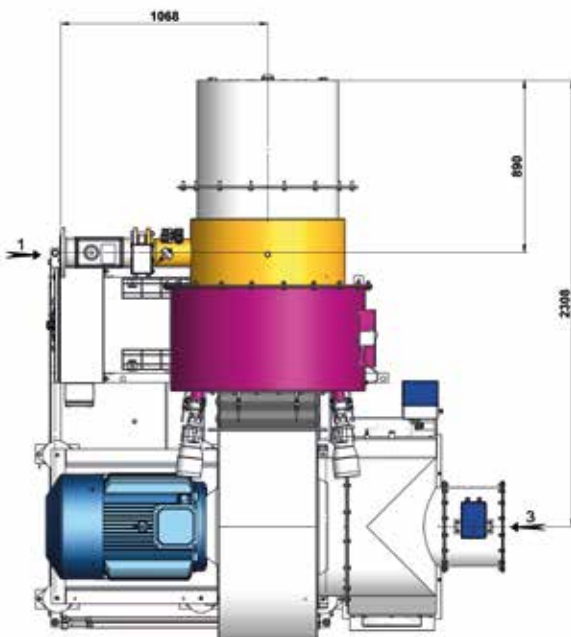
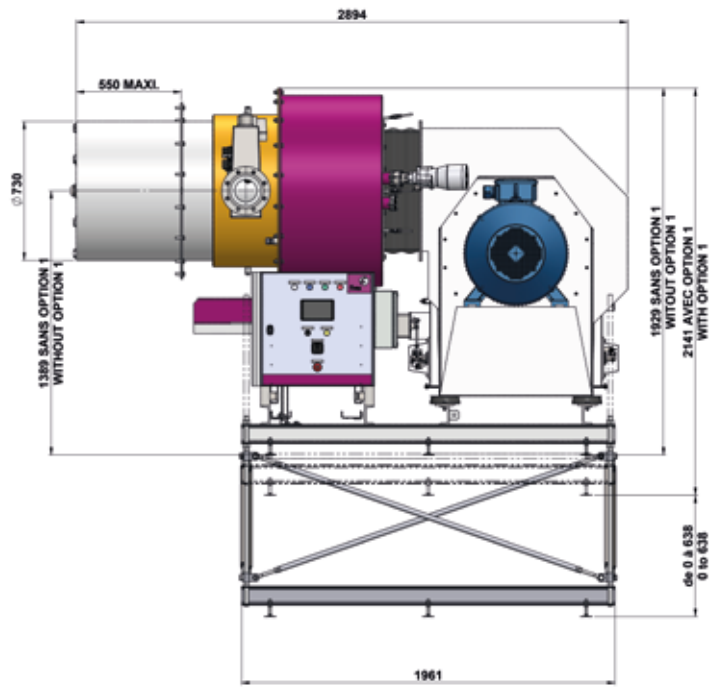
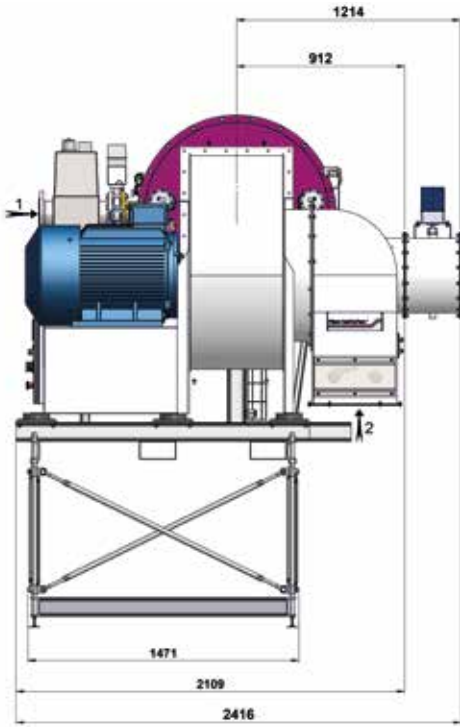

PIPING CONNECTIONS BOARD			
N°	FLUID	FLOW DIRECTION	DIMENSION N°3
1	NATURAL GAS	INLET	DN 125
2	COMBUSTION AIR	INLET	820 X 492
3	FGR	INLET	ID 400

Fives Pillard companies: France (Head Office) / Spain / Germany / China / India

France

Fives Pillard - 13, Rue Raymond Teissère, 13272 MARSEILLE Cedex 8 - France
Tel: 04 97 80 90 21 - Fax: 04 91 25 72 71 - fp.sales@fivesgroup.com

Germany

Fives Pillard Deutschland GmbH Aarstrasse 168 - Postfach 1455 - 65222 TAUNUSSTEIN - Germany
Phone: +49 (0)6128 2420 - Fax: +49 (0)6128 242 112 - info@fives-pillard.de

Spain

Fives Pillard Espana - S.A. C/, Almazara, 7 (Pol. Industrial) - 28760 TRES CANTOS (MADRID) - Spain
Tel: +34 91 803 1284 - Fax: +34 91 804 3261 - fivespillardespana@fivesgroup.com

P.R. China

上海法孚自动化成套设备有限公司 (北京分公司) - Shanghai Fives Automation & Processing Equipment (Beijing Office) Co. Ltd. Room 0805, Zhongyu Plaza, A6 GongtiBei Road Chaoyang District - BEIJING, 100027 - China
Tel: +86 10 6569 8800 - Fax: +86 10 6569 8803 - pillard-china.info@fivesgroup.com

India

Fives Combustion Systems Pvt., Ltd. - Plot No. 230, Padra-Jambusar, Highway Dabhasa-391 440 District Vadodara - GUJARAT - India
Tel: +91-2662 618200/244459/244482/244483 - Fax: +91-2662 618222 - fivescombustionsystems@fivesgroup.com

 Follow us on LinkedIn
[linkedin.com/company/fives-pillard](https://www.linkedin.com/company/fives-pillard)

www.fivesgroup.com

fives ultimate machines
ultimate factory