

Datasheet - Metric

ITAS INTENSITYFLAME BURNERS

MODEL IF0145-GAS

Parameter	Value
Maximum Capacity input [kWlhv] <i>(Air pre-heating limits the maximum capacity)</i>	14500
Minimum Capacity input [kWlhv]	1100
Fuels <i>(Contact Fives ITAS S.p.A. for dual gas or oil options)</i>	Natural gas, propane, butane, mixed gases <i>(Contact Fives ITAS S.p.A. for using special gases)</i>
Pressure drop gas gun [mbar] <i>(maximum capacity)</i>	Natural gas: 103,3 Propane: 41,6
Nominal combustion Air Inlet [Nm ³ /h]	17 400
Air inlet pressure [mbar] <i>(At nominal input, 20°C)</i>	22
Lambda [-]	1,2 to 1,7
Combustion air temperature [°C]	Standard <20 On request <300
Fuel guns	Single - Gun for single gas Double - Gun for dual gas
Combustor options	Alloy (AISI 310) Refractory (83% alumina air bond)
Maximum chamber temperature [°C]	Alloy combustor: 600 (@ Lambda 1,4) Refractory combustor: 900
Flame dimensions [mm] <i>(Measured from outlet of combustor)</i>	Length 4000 Diameter 1300
Ignition	Raw gas pilot, natural gas or propane
Pilot	Capacity [kW]: 145 Gas pressure NG [mbar]: 30 Gas pressure Propane [mbar]: 12,5
Flame Monitoring	UV scanner or Infrared scanner
Emissions	On request
Installation position	Horizontal Vertical up Vertical down (use a continuous fan operation)
Weight [kg]	Burner with alloy combustor: 470 Burner with refractory: 970

Notes:

- All data are based on net calorific values = lhv
- All information is based on common practice for gas and air pipe design.
Contact Fives ITAS S.p.A. if you need further support
- All inputs are based on laboratory testing at neutral chamber conditions
- Natural gas: lhv = 9,97 kWh/Nm³; d=0,56
- Propane: lhv 26,3 kWh/Nm³; d=1,58

1/4

The information provided on this brochure is for information purposes only and does not constitute any legal obligation or a warranty, expressed or implied, concerning quality, marketability or suitability for a specific purpose.

1. OPERATION CURVE (AMBIENT COMBUSTION AIR)

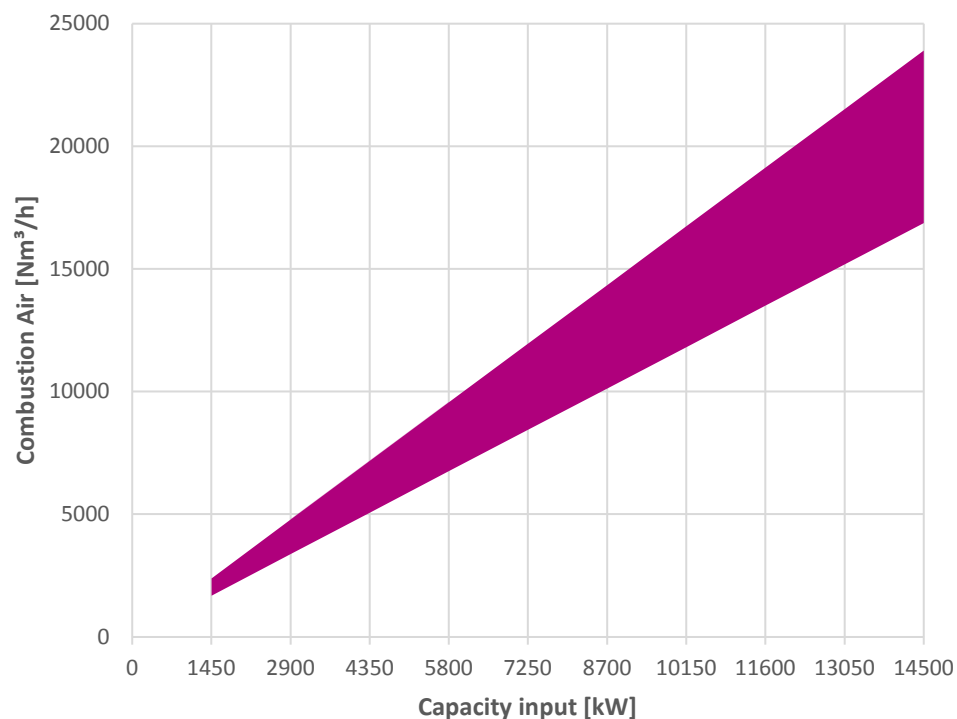

2. COMBUSTION AIR PRESSURE DROP

Pressure drop shall be taken between the chamber and wind box pressure tap (tap B)

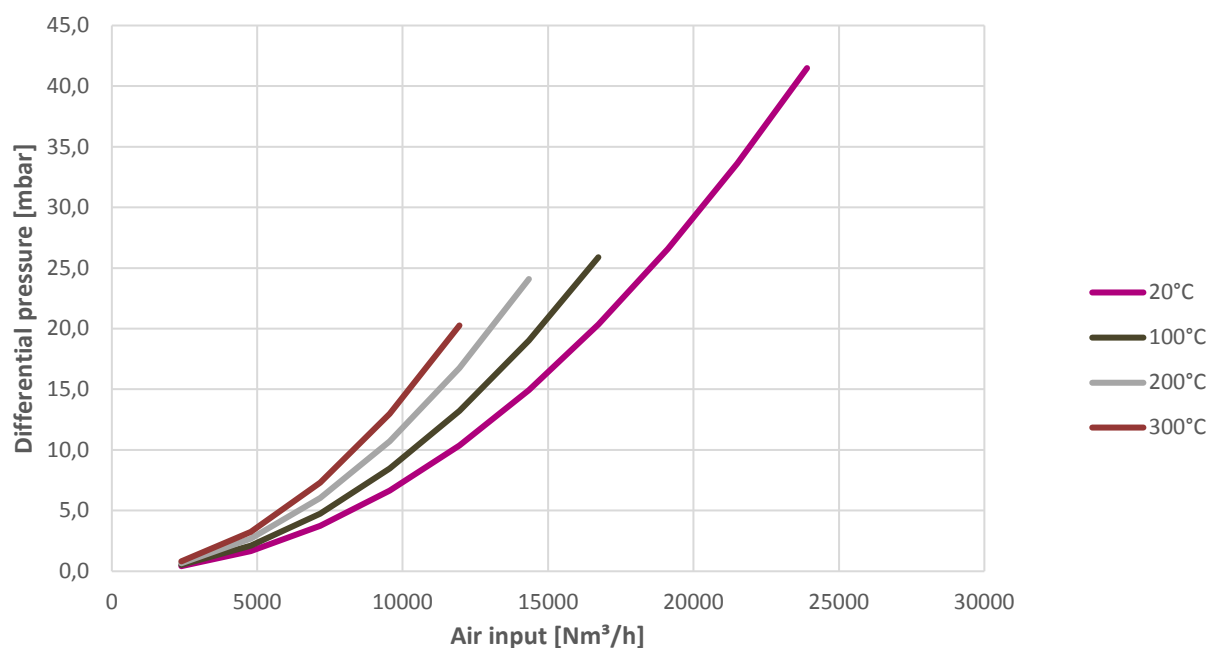

2/4

The information provided on this brochure is for information purposes only and does not constitute any legal obligation or a warranty, expressed or implied, concerning quality, marketability or suitability for a specific purpose.

3. GAS GUN PRESSURE DROP

Pressure drop shall be taken as differential between the chamber and gas gun pressure tap A.

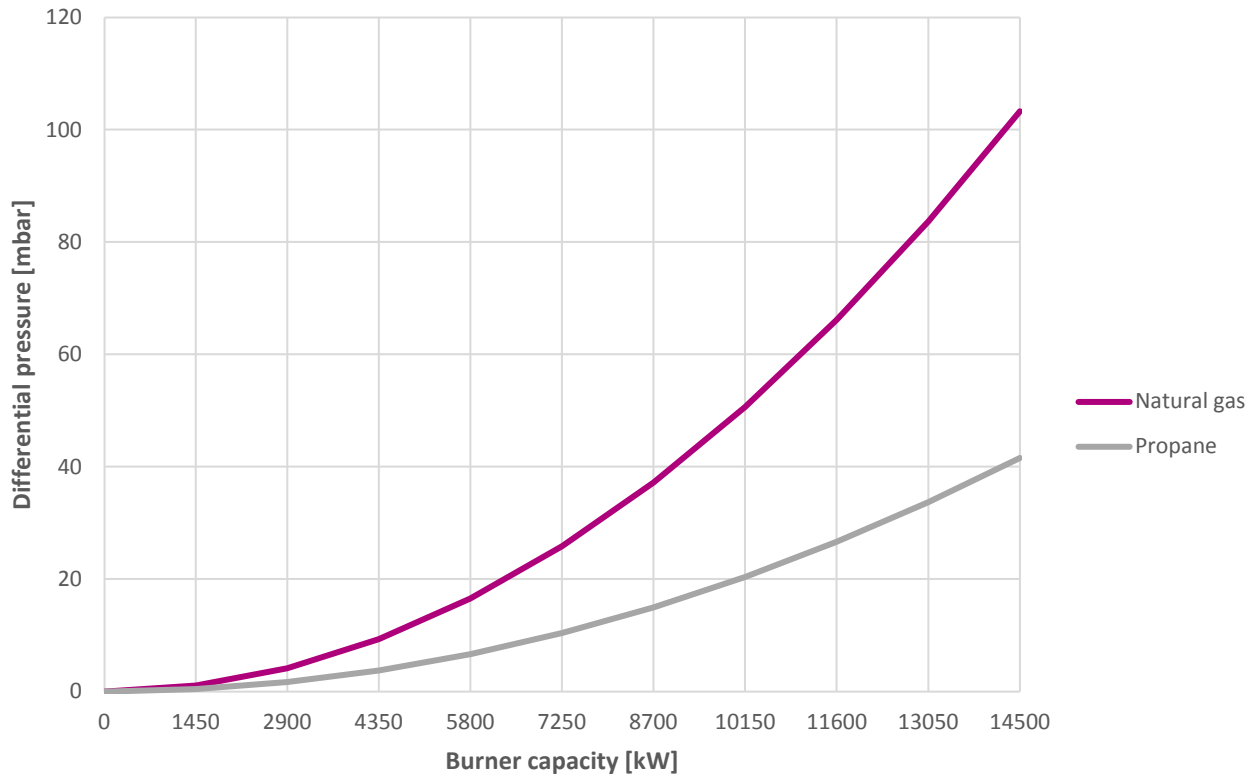

Note: Pressure drop curves shall be used as a guide for setting up burner. It is recommended to use fuel flow measurements for determining actual fuel flows.

4. DIMENSIONS

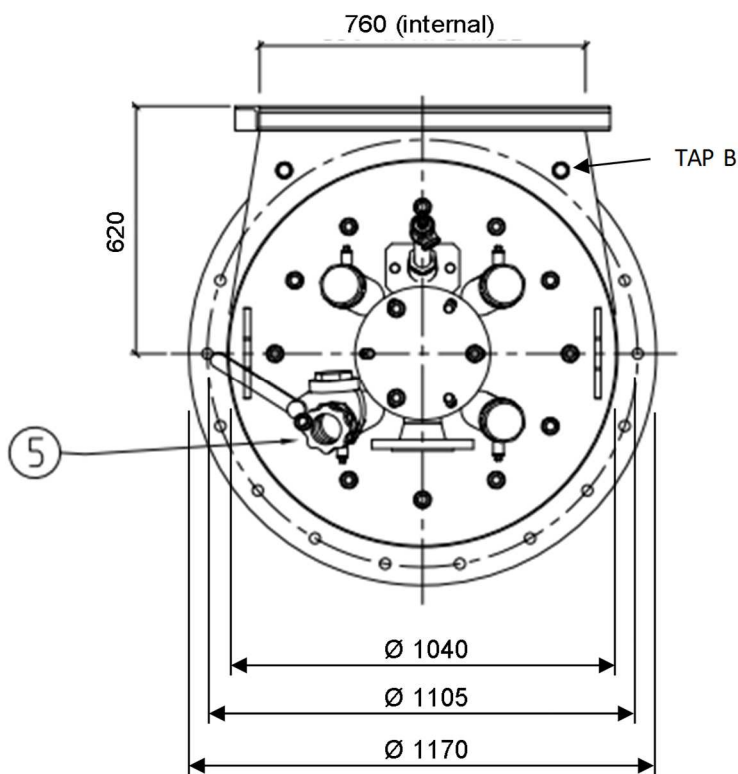
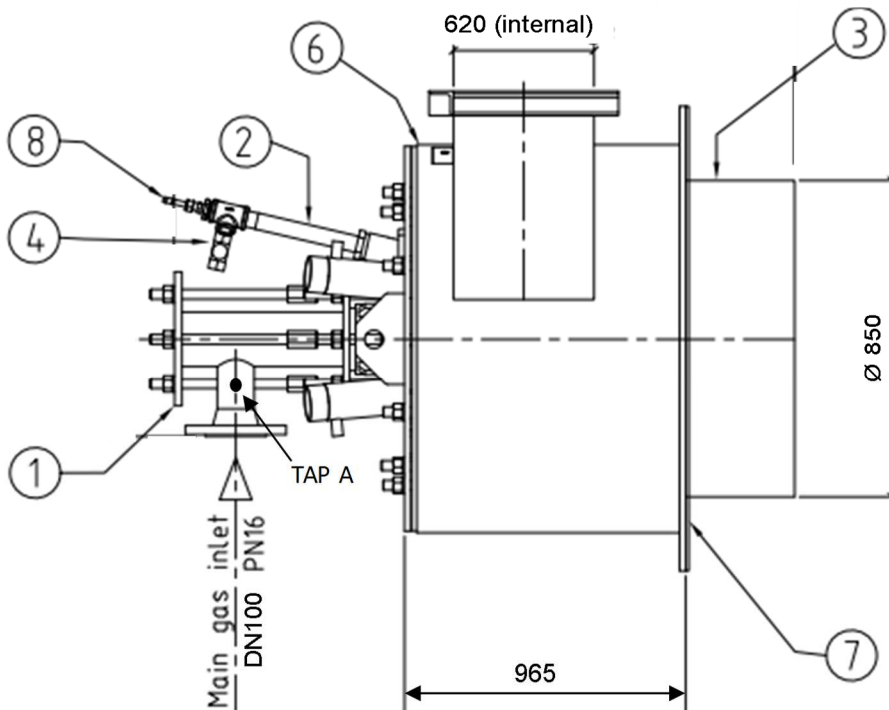

Pos	Description
1	Gas gun
2	Pilot burner
3	Combustor (refractory/alloy)
4	Pilot gas adjusting tee
5	Sight glass with valve
6	Burner body
7	Burner gasket
8	Ignition spark rod