

ITAS INTENSITYFLAME BURNERS

MODEL IF0115-GAS

| Parameter | Value |
|--|---|
| Maximum Capacity input [kWlhv] <i>(Air pre-heating limits the maximum capacity)</i> | 11500 |
| Minimum Capacity input [kWlhv] | 800 |
| Fuels <i>(Contact Fives ITAS S.p.A. for dual gas or oil options)</i> | Natural gas, propane, butane, mixed gases <i>(Contact Fives ITAS S.p.A. for using special gsses)</i> |
| Pressure drop gas gun [mbar] <i>(maximum capacity)</i> | Natural gas: 58,2 Propane: 23,4 |
| Nominal combustion Air Inlet [Nm ³ /h] | 13800 |
| Air inlet pressure [mbar] <i>(At nominal input, 20°C)</i> | 23,7 |
| Lambda [-] | 1,2 to 1,7 |
| Combustion air temperature [°C] | Standard <20 On request <300 |
| Fuel guns | Single - Gun for single gas Double - Gun for dual gas |
| Combustor options | Alloy (AISI 310) Refractory (83% alumina air bond) |
| Maximum chamber temperature [°C] | Alloy combustor: 600 (@ Lambda 1,4) Refractory combustor: 900 |
| Flame dimensions [mm] <i>(Measured from outlet of combustor)</i> | Length 3700 Diameter 1200 |
| Ignition | Raw gas pilot, natural gas or propane |
| Pilot | Capacity [kW]: 115 Gas pressure NG [mbar]: 30 Gas pressure Propane [mbar]: 12,5 |
| Flame Monitoring | UV scanner or Infrared scanner |
| Emissions | On request |
| Installation position | Horizontal Vertical up Vertical down (use a continuous fan operation) |
| Weight [kg] | Burner with alloy combustor: 390 Burner with refractory: 770 |

Notes:

- All data are based on net calorific values = lhv
- All information is based on common practice for gas and air pipe design.
Contact Fives ITAS S.p.A. if you need further support
- All inputs are based on laboratory testing at neutral chamber conditions
- Natural gas: lhv = 9,97 kWh/Nm³; d=0,56
- Propane: lhv 26,3 kWh/Nm³; d=1,58

1. OPERATION CURVE (AMBIENT COMBUSTION AIR)

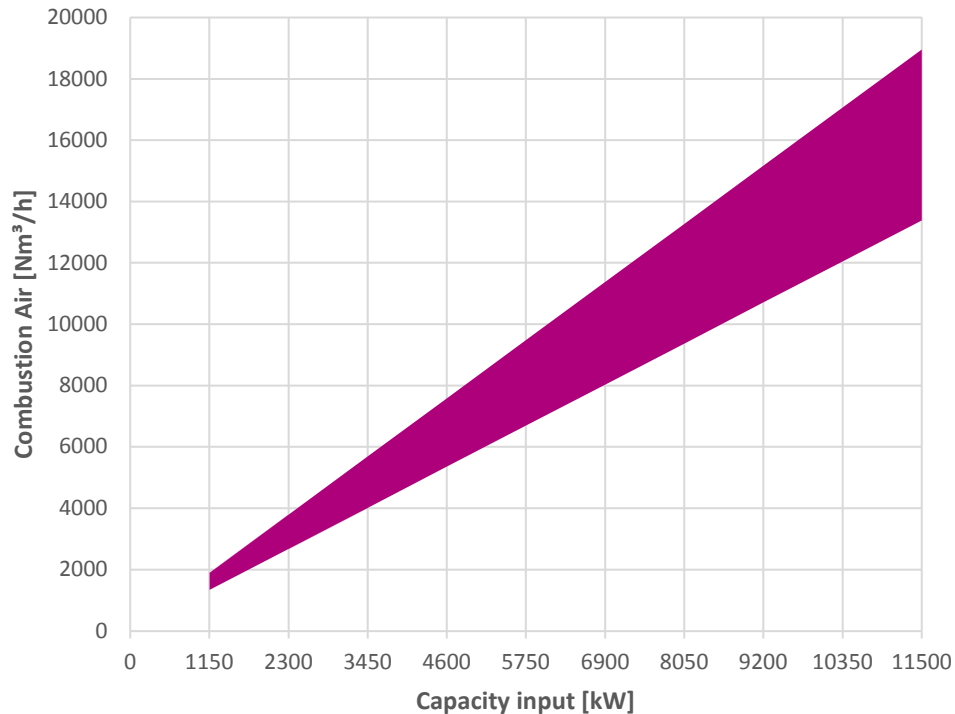

2. COMBUSTION AIR PRESSURE DROP

Pressure drop shall be taken between the chamber and wind box pressure tap (tap B)

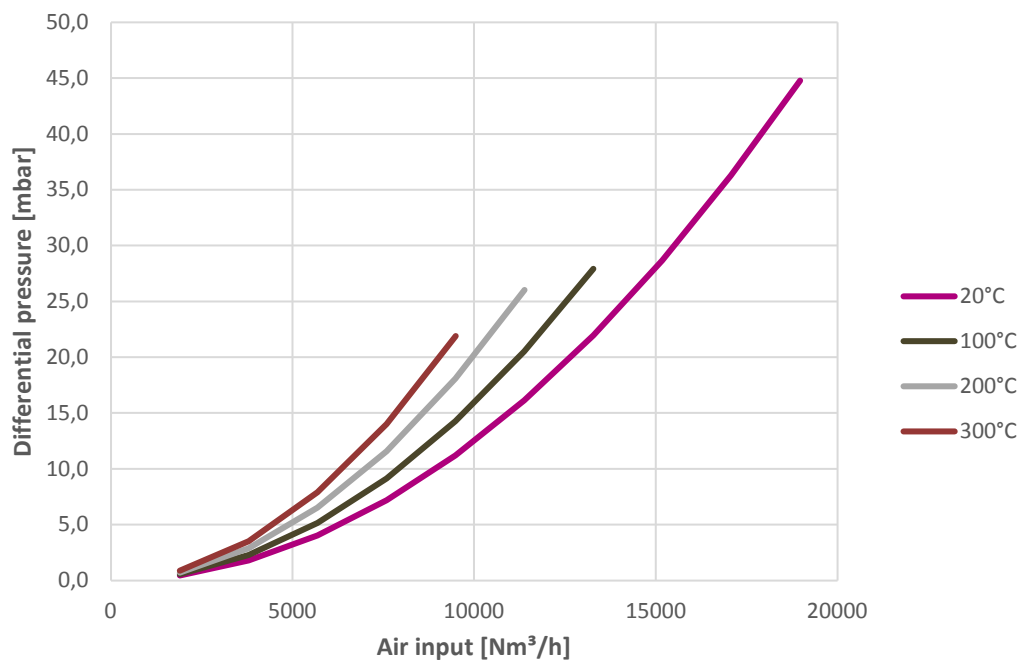

2/4

The information provided on this brochure is for information purposes only and does not constitute any legal obligation or a warranty, expressed or implied, concerning quality, marketability or suitability for a specific purpose.

3. GAS GUN PRESSURE DROP

Pressure drop shall be taken as differential between the chamber and gas gun pressure tap A.

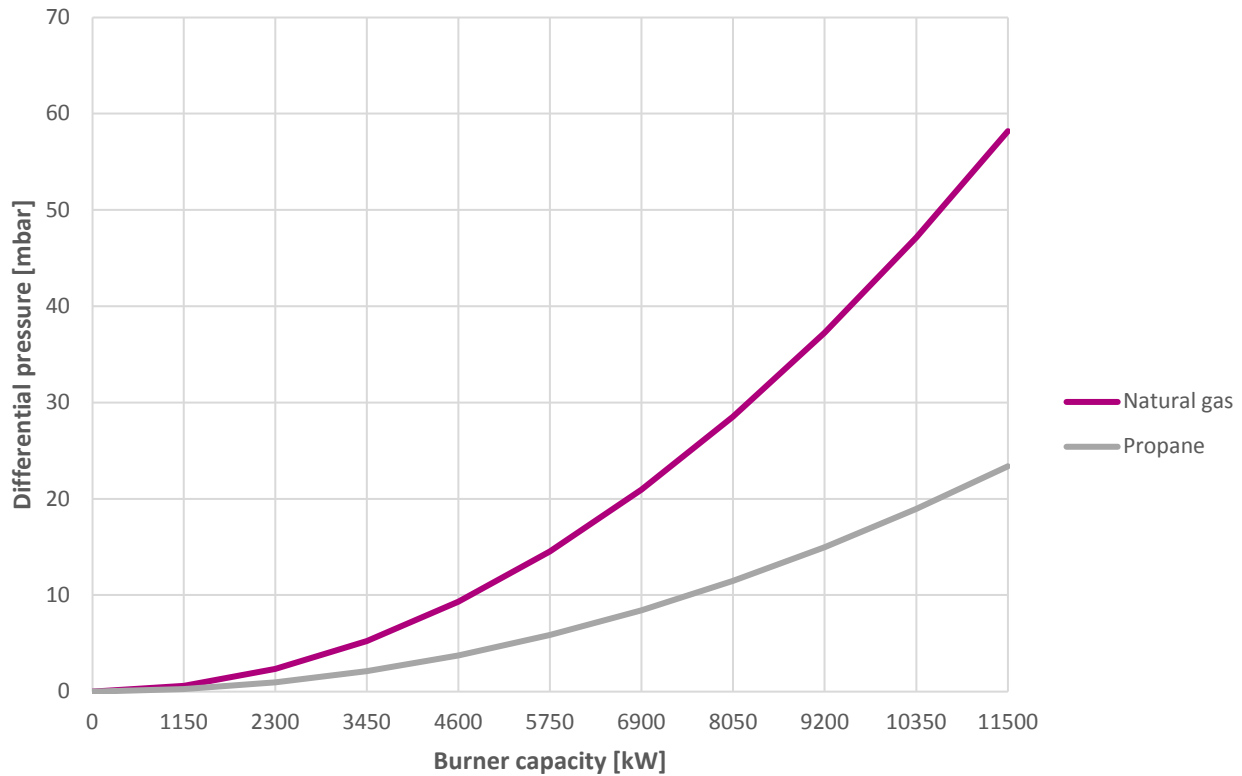

Note: Pressure drop curves shall be used as a guide for setting up burner. It is recommended to use fuel flow measurements for determining actual fuel flows.

4. DIMENSIONS

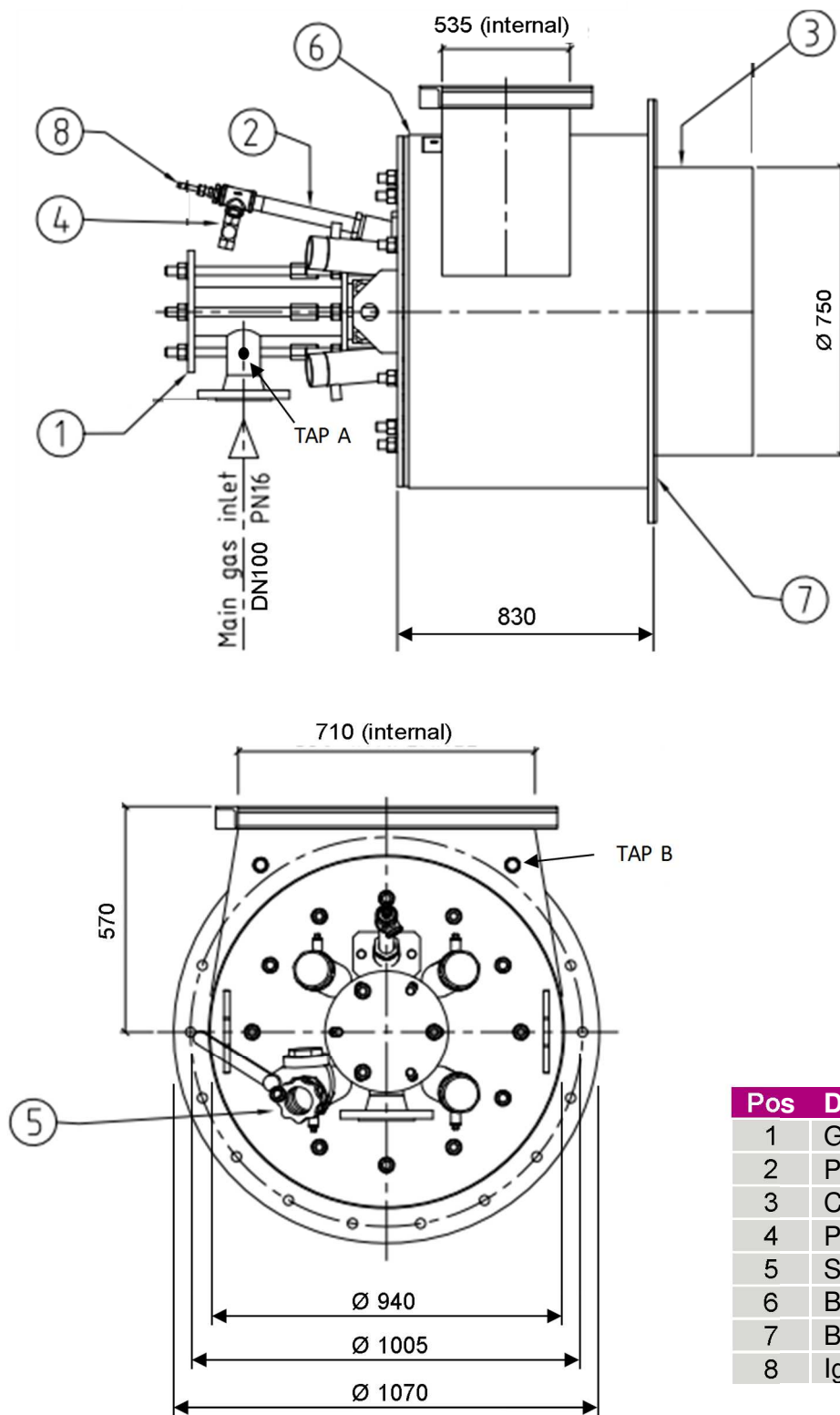

| Pos | Description |
|-----|------------------------------|
| 1 | Gas gun |
| 2 | Pilot burner |
| 3 | Combustor (refractory/alloy) |
| 4 | Pilot gas adjusting tee |
| 5 | Sight glass with valve |
| 6 | Burner body |
| 7 | Burner gasket |
| 8 | Ignition spark rod |